

## Modular System Motor

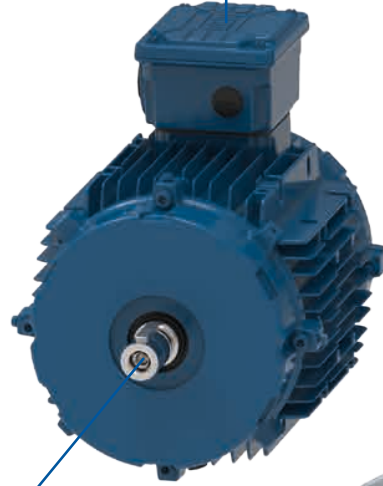



Terminal box designs  
page 386



Brake systems  
and back stops  
page 389



Encoder systems  
page 400

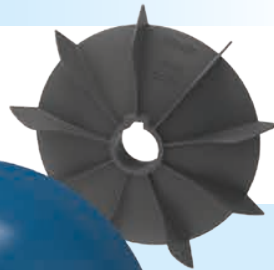

Ventilation systems  
page 403

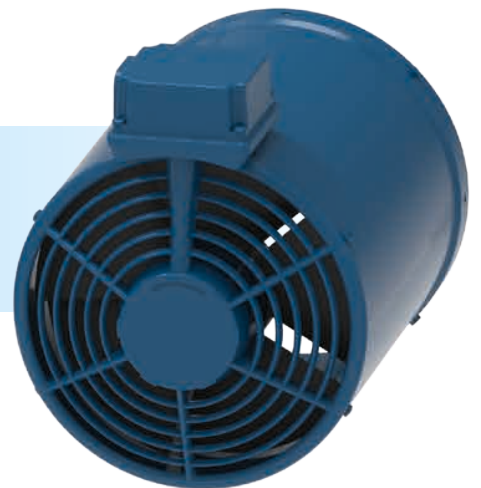



Motor series 11  
with aluminium housing  
(frame sizes 63 - 132)



Motor series 22  
with cast iron housing  
(frame sizes 160 - 250)

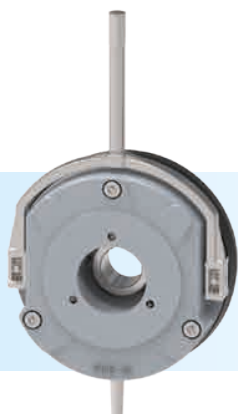

## The modular motor system

Our motor system is an optimised and modularly designed kit. It includes harmonised modules like brakes, encoders, forced ventilation and connecting systems which are combined to the customer's requirements.

The significant advantage of this concept offers fast and reliable delivery times, not only to our local customers but also internationally, because WEG's competent sales network and assembling centres guarantee the availability of components worldwide.

Detailed description of the motor modules see from page 385.

## The modular system motor

Due to special windings and clever connecting systems it's possible to use the same motor all over the world. Just a change of connection (4 possible options) and the motor can do its job reliably in Europe, USA or Far East, from 110 V to 690 V, 50 Hz and 60 Hz.

### The modular system motor is available in two energy efficiency classes:

IE1: Series 11N, IEC frame sizes 63 to 80 (up to 0.55 kW)

IE3: Series 11P (aluminium), IEC sizes 80 to 132 (0.75 - 9.2 kW) and series 22P (cast iron), IEC sizes 160 and 250 (11-75 kW)

Motors in energy efficiency class IE4 on request

### Advantages

- Wide voltage range
- Switchable to all usual voltages worldwide:
  - 110-480 V - 50/60 Hz up to and including frame size 100
  - 190-690 V - 50/60 Hz for frame sizes 112 to 250
- Frequency inverter operation 100/120 Hz
- Ambient temperature -20 to +40 °C
- Nameplate with 50/60 Hz data
- Flexible adjustment of the terminal box
- Reinforced bearings (integral motor)
- Shaft system for immediate assembling of motor modules, like encoders, brakes, back stop, etc.
- Standard degree of protection IP55
- Thermal protection with bimetal switch and/or PTC thermistor
- Thermal class F
- System motor, prepared for flexible assembling of motor modules
- Certified for worldwide distribution: CE, CSA, UL, EAC

M

### The ideal motor for frequency inverter operation

Switchable to 100/120 Hz. Simply switch over and use the double output.

The excellent combination of the modular system motor and variable speed drives by WEG (type CFW for various applications and decentralised motor drive MW500) enables drive systems with wide speed range.

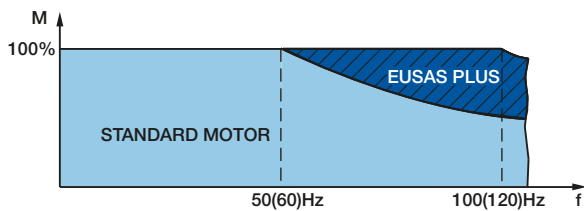

Rated torque up to double rated speed

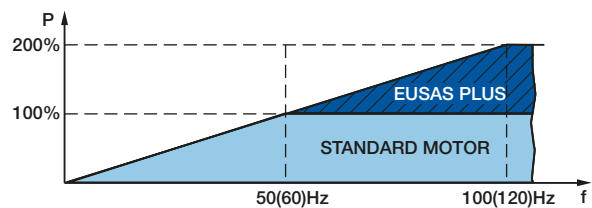

Two times rated power at double rated speed

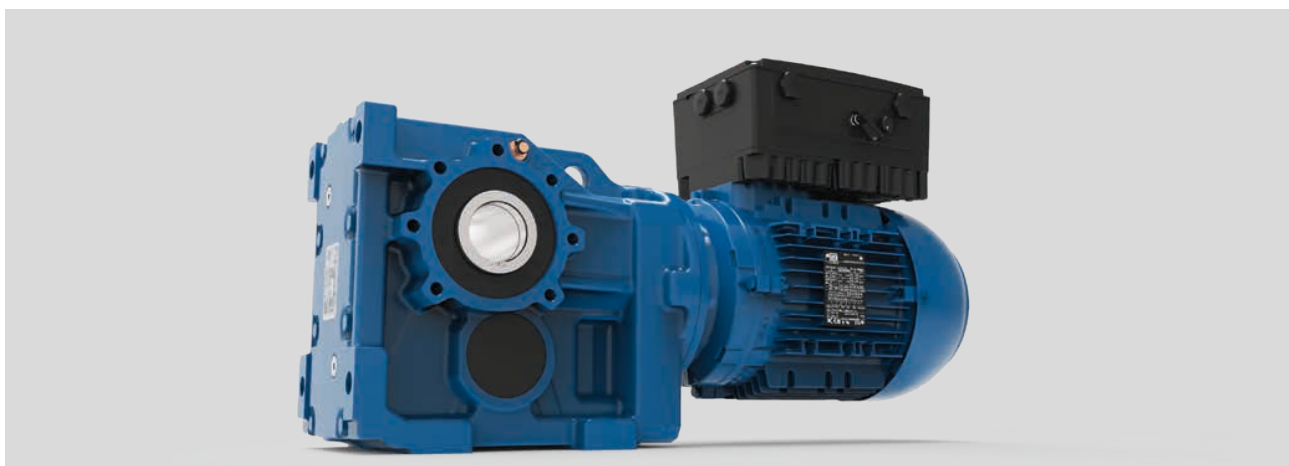

WEG20 geared motor with decentralised motor drive MW500



## Type code

11P-EX-L100L-04F-LT-TH-SH-K1-KB-MIP-BR..-SG-FL-SD

1 2 3 4 3 5 6 7 8 9 10 11 12 13 14 15 16

- |           |                                 |   |
|-----------|---------------------------------|---|
| <b>1</b>  | Motor series:                   | 11N = Aluminium motor in energy efficiency class IE1, frame sizes 63 - 80 (up to 0.55 kW)<br>11P = Aluminium motor in energy efficiency class IE3, frame sizes 80 - 132 (0.75 - 9.2 kW)<br>22P = Cast iron motor in energy efficiency class IE3, frame sizes 160 - 250 (11 - 75 kW) |
| <b>2</b>  | ATEX execution:                 | when operated in explosive atmospheres, see page 368  |
| <b>3</b>  | Stator length:                  | L.<br>.S<br>.S/L<br>.S/M<br>.M<br>.L  |
| <b>4</b>  | IEC frame size:                 | 63      132<br>71      160<br>80      180<br>90      200<br>100     225<br>112     250  |
| <b>5</b>  | Number of poles:                | 04 = 4 poles<br>06 = 6 poles  |
| <b>6</b>  | Power indicator:                | D<br>E<br>F<br>G  |
| <b>7</b>  | High/Low temperature execution: | see page 385  |
| <b>8</b>  | Temperature control:            | see page 385  |
| <b>9</b>  | Anti-condensation heating:      | see page 385  |
| <b>10</b> | Climatic protection:            | see page 386  |
| <b>11</b> | Drain:                          | see page 386  |
| <b>12</b> | Terminal box designs:           | see page 386  |
| <b>13</b> | Brake systems, back stop:       | see page 389  |
| <b>14</b> | Encoder systems:                | see page 400  |
| <b>15</b> | Ventilation systems:            | see page 403  |
| <b>16</b> | Additional modules:             | see page 405  |



# Options

## 1. Basic execution

Description	Key	Page	IEC frame size														
			63	71	80	90	100	112	132	160	180	200	225	250			
Switchable voltage (4 connections)	-	368															
Temperature controller for switch off (+155 °C)	TH	385															
PTC thermistor protection for switch off (+155 °C)	TF	385															
Thermal class F (up to +155 °C)	-	368															
Fixed bearing NDE	-	-															
Fixed bearing DE	-	-	-	-	-	-	-	-	-	-	-	-	-	-	-	-	-
Degree of protection IP55	-	17															
Certifications (CE, EAC, UL, CSA)	-	-															

## 2. Electrical options

Description	Key	Page	IEC frame size														
			63	71	80	90	100	112	132	160	180	200	225	250			
Special voltage SPECI-Volt	-	368															
Temperature controller for warning and switch off	2TH	385															
PTC thermistor protection for warning and switch off	2TF	385															
Temperature sensor KTY	KTY	385															
Temperature sensor Pt100	-	-															
Anti-condensation heating 230 V	SH	385	-														
Thermal class H (up to +180 °C)	-	-															

## 3. Mechanical options

Description	Key	Page	IEC frame size														
			63	71	80	90	100	112	132	160	180	200	225	250			
Degree of protection IP56	-	17															
Degree of protection IP65	-	17															
Degree of protection IP66	-	17															
Degree of protection IP67	-	17															
High temperature execution (max. +80 °C ambient temperature)	HT	385															
Low temperature execution	LT	385															
ATEX zone 2+22: II 3G Ex ec IIC T3 Gc / II 3D Ex tc IIIC T125°C Dc	EX	368															
Humidity protection K1	K1	386															
Corrosion protection K2	K2	386															
Drain	KB	386															
Multipin box	MIP	386															
Multi-plug-connect systems	MIG..	387													-	-	-
Multi-plug-connect system for forced ventilation	MIG10-FL	387															
Non-ventilated without NDE shaft end	U	404															
Non-ventilated with NDE shaft end	UW	404															
Different position of the terminal box	-	-															
Relubrication	-	-	-	-	-	-	-	-	-	-	-	-	-	-	-	-	-

	Standard		Special execution (on request)
	Optional		Not available

M

#### 4. Options - motor modules

Description	Key	Page	IEC frame size														
			63	71	80	90	100	112	132	160	180	200	225	250			
Spring loaded brake - IP55, 24 V	BR..	393															
Spring loaded brake - IP55, 102 V	BR..	393															
Spring loaded brake - IP55, 195 V	BR..	393															
Double spring loaded brake in low noise execution	BBRHGD..	394	-														
Totally closed spring loaded brake - IP66	BRGH..	395	-														
Manual release for brake	(BR)H..	393	1)														
Locking device for manual release	(BR)HA..	393	1)														
Corrosion protection IP55 for brake	(BR)R..	393															
Dust protection IP65 for brake	(BR)S..	393	1)														
Corrosion and dust protection IP65 for brake	(BR)SR..	393	1)														
Brake in low noise execution	(BR)GD..	393	1)														
Micro switch	(BR)M	393	1)														
Anti-condensation heating for brakes	-	395	-	-													
Fast excitation rectifier	-	397															
Back stop KKM	KKM	399					-	-	-	-	-	-	-	-	-	-	-
Back stop RSM	RSM	399	-	-	-	-											
Encoder outside the fan cover	I.	400															
Encoder inside the fan cover	S.	400	-														
Encoder (1024 pulses, HTL/TTL, IP66)	.G	400	I. S.														
Mating plug for encoder without cable	-	-	I. S.														
Mating plug for encoder with cable	-	-	I. S.														
SINCOS encoder	.C	400	-	-													I. S.
Resolver	.R	400	-														-
Special encoder	.A	401															
SSI multiturn encoder	SS	401	-														
Heavy Duty encoder	SV	401	-	-	-												
Forced ventilation (TEFV)	FL	403															
Fly wheel fan	ZL	404	-									-	-	-	-	-	-
Hand wheel	HR	405	-														
Protection cap	SD	405															
Protection cap for encoders	ID	405	-	-	-												
Second shaft end - module shaft	ZWM	406	-														
Second shaft end - solid shaft	ZWV	406														-	-



#### 5. Additional options

Description	Key	Page	IEC frame size														
			63	71	80	90	100	112	132	160	180	200	225	250			
Special nameplate (aluminium)	-	-															
Second nameplate (not fixed, aluminium or stainless steel)	-	-															
Metal fan	ZM	404															
Vibration severity grade "B" (reduced) according to DIN IEC 60034-14	-	368															
Wide range grease (-40 °C to +175 °C)	-	-															

1) not possible with 2 Nm brake

- Standard
- Special execution (on request)
- Optional
- Not available

## General information

Frame size	63	71	80	90S/L	(L)100L	112M	(L)132M,S	160M,L	180M,L	200L	225S/M	250S/M	
<b>Mechanical features</b>													
Mounting form	B14R						B5R						
Housing material	aluminium EN AC-46100						cast iron EN GJL-200						
Degree of protection	IP55												
Grounding	simple grounding - one inside the terminal box										double - in the terminal box and on the frame		
Cooling method	fan - IC411 (TEFC)												
Fan material	polypropylen										aluminium		
Fan cover material	sheet steel												
Endshields material	aluminium EN AC-46100 *						cast iron EN GJL-200						
Drain	rubber drain plug												
Bearings	Locking	without bearing cap with circlip - NDE						without bearing cap with circlip - DE			internal + external bearing cap and spring washers - NDE		
	DE	6203 ZZ	6204 ZZ	6205 ZZ	6305 ZZ	6207 ZZ	6307 ZZ	6309 ZZ	6309 ZZ-C3	6312 ZZ-C3	6314 ZZ-C3	6314 ZZ-C3	6316 ZZ-C3
	NDE	6201 ZZ	6203 ZZ	6203 ZZ	6205 ZZ	6206 ZZ	6206 ZZ	6308 ZZ	6209 ZZ-C3	6211 ZZ-C3	6212 ZZ-C3	6314 ZZ-C3	6314 ZZ-C3
Shaft seal	Type	radial shaft seal											
	DE	17x30x7	20x30x7	25x40x7	25x40x7	35x52x7	35x52x7	45x60x8	45x60x8	60x90x10	60x90x10	70x90x10	70x90x10
	NDE	12x22x7	17x28x5	17x28x5	25x35x7	30x40x4	30x40x4	40x56x8	45x62x7	55x70x8	60x75x8	70x85x8	70x85x8
	Material	NBR											
Lubrication	Type of grease	Mobil Polyrex EM											
	Grease fitting	without grease fitting											
Terminal block	9 poles												
Terminal box material	aluminium EN AC 47000						cast iron EN GJL-200						
Cable entry	Main	2 x M25x1.5				2 x M32x1.5			2 x M40x1.5	2 x M50x1,5	2 x M50x1,5	2 x M63x1,5	2 x M63x1,5
	Accessory	2 x M16x1.5											
	Plug	threaded plug for transport and storage; cable gland optional											
Shaft material	1.0511/1.1191 – C40/C45E – AISI 1040/45										1.7225 - 42CrMo4 - AISI 4140		
Direction of rotation	both directions												
Vibration	class A												
Nameplate material	stainless steel 1.4301 (AISI 304)												
Flange	FC-120					FC-160			FR-200 FR-250 FR-300 FR-400 FR-550	FR-250 FR-300 FR-400 FR-550	FR-300 FR-400 FR-550	FR-400 FR-550	FR-550
<b>Electrical features</b>													
Power [kW] 4 poles	0.12 - 0.18	0.25 - 0.37	0.55 - 0.75	1.1 - 1.5	2.2 - 3.0	4.0	5.5 - 9.2	11.0 - 15.0	18.5 - 22	30	45 - 55	75	
Power [kW] 6 poles	0.12	0.18 - 0.25	0.37 - 0.55	0.75	1.1 - 1.5	2.2	3.0 - 5.5	-	-	-	-	-	
Design	N												
Voltage / Frequency	Δ	220-240 V (50Hz) // 220-277 V (60Hz)					Δ		380-420 V (50 Hz) // 380-480 V (60 Hz)				
	ΔΔ	110-120 V (50 Hz) // 110-138 V (60Hz)					ΔΔ		190-210 V (50 Hz) // 190-240 V (60 Hz)				
	Y	380-420 V (50 Hz) // 380-480 V (60 Hz)					Y		660-690 V (50 Hz) // 660 V (60 Hz)				
	YY	190-210 V (50 Hz) // 190-240 V (60 Hz)					YY		330-365 V (50 Hz) // 330-415 V (60 Hz)				
Winding	Impregnation	dip										continuous flow impregnation	
	Insulation class	F (DT 80K)											

\* Except frame sizes L100L and L132M: endshield (NDE) made from cast iron EN GJL-200

## 1. Nameplate

The stainless steel plate is fixed on the frame and bears data for 50 Hz and 60 Hz. The information on the nameplate contains all relevant specifications of the product (see examples for motor frame sizes 90, 132 and 160).

WRG				14057615			
		M330015009A4YC12031G					
		~ 3 AL90S/L-04					
IP55		INS	CLF	ΔT 80	K S1	SF 1.00	AMB 40°C
V	Hz	kW	RPM	A	PF		
115 Δ / 200 Y Y	50	1.5	1450	11.0 / 6.30	0.80		
230 Δ / 400 Y				5.50 / 3.15			
132 Δ / 230 Y Y	60		1755	9.72 / 5.58	0.78		
265 Δ / 460 Y				4.84 / 2.78			
50Hz	IE3	86.0 (100%)	86.0 (75%)	84.0 (50%)			
60Hz		86.5 (100%)	85.5 (75%)	82.5 (50%)			
		IEC 60034-1 MOD.TE0=AOX0\$0000300647					
NEMA Eff 86.5%		2.0HP 460 V 60Hz 1755 RPM					
2.78 A PF 0.78		DES A CODE L SF 1.15 CC029A					
→ 6305-ZZ → 6205-ZZ		MOBIL POLYREX EM		23 kg			
2753 Markt Piesting, Austria							

WRG				14057670			
		M330055013A48C16031G					
		~ 3 AL132S-04					
IP55		INS	CLF	ΔT 80	K S1	SF 1.00	AMB 40°C
V	Hz	kW	RPM	A	PF		
200 Δ / 346 Y Y	50	5.5	1465	20.6 / 11.9	0.85		
400 Δ / 690 Y				10.3 / 5.97			
230 Δ / 400 Y Y	60		1765	18.1 / 10.4	0.83		
460 Δ / -				9.05 / -			
50Hz	IE3	90.7 (100%)	90.7 (75%)	90.0 (50%)			
60Hz		91.7 (100%)	91.0 (75%)	88.5 (50%)			
		IEC 60034-1 MOD.TE0=AOX0\$0000302360					
NEMA Eff 91.7%		7.5HP 460 V 60Hz 1765 RPM					
9.05 A PF 0.83		DES A CODE K SF 1.15 CC029A					
→ 6309-ZZ → 6308-ZZ		MOBIL POLYREX EM		69 kg			
2753 Markt Piesting, Austria							

				M430110016G41R20010G							
				MOD.TE1BF0X0\$ IEC 60034-1							
		~ 3 160M-04		IP55		INS	CLF	ΔT 80	K S1	SF 1.00	AMB 40°C
V	Hz	kW	RPM	A	PF	Eff	100%	75%	50%		
200 Δ / 346 Y Y	50	11	1470	41.8 / 24.1	0.83	IE3	91.6	91.8	91.1		
400 Δ / 690 Y				20.9 / 12.1							
230 Δ / 400 Y Y	60		1775	36.9 / 21.2	0.81		92.4	92.2	91.0		
460 Δ / -				18.4 / -							
→ 6309-ZZ-C3 → 6209-ZZ-C3		MOBIL POLYREX EM		2753 Markt Piesting, Austria		NEMA Eff 92.4% 15HP 460 V 60Hz 1775 RPM		18.4 A PFO.81 Des A Code K SF 1.00 CC029A			
						Alt 1 000 m.a.s.l.		127 kg			

## 2. Voltage and frequency fluctuations

According to DIN EN 60034-1, a distinction is made between range A and range B (outside A) for voltage and frequency fluctuations. Range A and range B describe the permissible range in which frequency and voltage levels are permitted to deviate from the relevant measurement point (see illustration). The coordinate mean point "0" identifies the measurement point for the frequency and voltage in each case. The motor must be able to issue the rated torque in both ranges A and B.

### Range A

In continuous operation in range A, the characteristics are permitted to vary from the rated operation, and the heating at the limits of range A can be around 10 K higher.

### Range B

The deviations from the characteristics are permitted to be greater than in range A, the heating levels can be higher than at the measurement point. Duration and frequency of operation in range B should be limited. Corrective measures, e.g. power reduction, should be provided. If a machine has multiple rated voltages or a rated voltage range, the permissible voltage and frequency fluctuations apply for each individual value of the rated voltage.

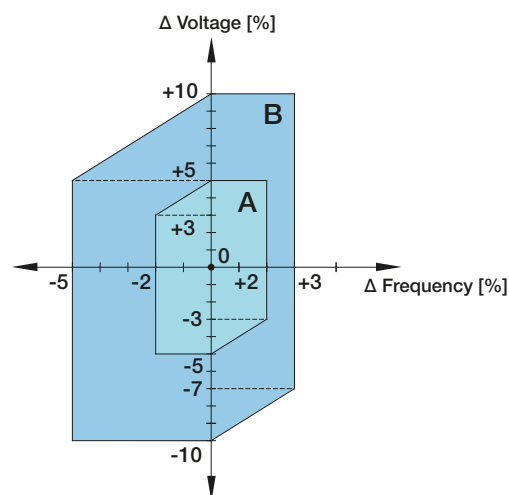

Ranges A and B according to DIN EN 60034-1



### 3. Modes of operation

Duty type according to DIN EN 60034-1 and VDE 0530-1.

The duty type is designated by the abbreviations S1 to S10. For the duty types S4, S5 and S7 the duty cycles/hour (c/h) and the factor of inertia  $F_I$  should also be stated at the bottom.

The factor of inertia  $F_I$  is the ratio of the total load moment of inertia (referred to the motor shaft) and the motor moment of inertia, to the motor moment of inertia, i.e.

$$F_I = \frac{\sum J_{ex.red} + J_{mot}}{J_{mot}}$$

Definition		Example
S1	Continuous running duty with constant load	S1
S2	Short-time duty with constant load Duration of operation under rated conditions (recommended values: 10, 30, 60 or 90 min)	S2 10 min
S3	Intermittent periodic duty. Motor temperature not affected by starting operation Cyclic duration factor (recommended values: 15, 25, 40 or 60 %): Cycle duration (10 min unless otherwise stated)	S3 25 % 60 min
S4	Intermittent periodic duty. Motor temperature affected by starting operation Cyclic duration factor (recommended values: 15, 25, 40 or 60 %): Indication of the duty cycles per hour and of the factor of inertia $F_I$	S4 40 % 200, $F_I=2$
S5	Intermittent periodic duty. Motor temperature affected by starting operation and electric braking Cyclic duration factor (recommended values: 15, 25, 40 or 60 %): Indication of the duty cycles per hour and of the factor of inertia $F_I$	S5 15 % 300, $F_I=1$
S6	Continuous operation periodic duty. Cyclic duration factor (recommended values: 15, 25, 40 or 60 %): Cycle duration (10 min unless otherwise stated)	S6 25 % 60 min
S7	Continuous operation with starting and electric braking Indication of the duty cycles per hour and of the factor of inertia $F_I$	S7 200, $F_I=1$
S8	Continuous operation with related load/speed changes (Sequence of similar cycles) Speeds during the duty cycle Periods for which these speeds are maintained during the duty cycle Indication of the factor of inertia $F_I$	S8 3000 <sup>min-1</sup> , 10 min 1500 <sup>min-1</sup> , 15 min $F_I=1.5$
S9	Continuous operation duty with unrelated load/speed changes	S9
S10	Duty with discrete constant loads and speed	S10 $F_I=0.6$

Legend see page 396.

### 4. Rated power according to VDE 0530-1

The listed rated power of the motor corresponds to the output power according to VDE 0530-1 for continuous operation S1, frequency 50/60 Hz, max. ambient temperature +40 °C, max. altitude 1000 m above sea level.

According to this standard at rated values (voltage and frequency) the motors may be overloaded for two minutes by 1.5 times the rated current, without damage of the winding.

The motors are calculated by rated values according to thermal class B, but produced in class F and by operation with rated values fit for higher loads:

- a. At rated power and rated voltage the ambient temperature may be increased from +40 °C to +60 °C.
- b. Provided that ambient temperature does not exceed +40 °C, the normal capacity in continuous operation can be increased by appr. 10 %.

All technical data stated applies to rated frequency of 50 Hz and supply voltage of 400 V rated voltage at rated power. If the load changes, the stated values will deviate to higher or lower.



## 5. Power correction factors

S2			
Time [min]	Motor frame size	Poles	
		2	4-8
15	63 - 132	1.20	1.25
30		1.05	1.10
60		1.00	1.00
15	160 - 200	1.40	1.45
30		1.20	1.25
60		1.10	1.10
15	225 - 250	1.45	1.45
30		1.30	1.30
60		1.15	1.15

S3			
DC [%]	Motor frame size	Poles	
		2	4-8
15	63 - 132	1.15	1.40
25		1.10	1.30
40		1.05	1.20
60		1.03	1.10
15	160 - 200	1.30	1.40
25		1.20	1.30
40		1.10	1.20
60		1.05	1.10
15	225 - 250	1.35	1.40
25		1.25	1.30
40		1.15	1.20
60		1.05	1.10

S6			
DC [%]	Motor frame size	Poles	
		2	4-8
15	63 - 132	1.20	1.30
25		1.15	1.25
40		1.10	1.20
60		1.05	1.15
15	160 - 200	1.25	1.30
25		1.20	1.25
40		1.15	1.20
60		1.10	1.15
15	225 - 250	1.30	1.35
25		1.25	1.30
40		1.15	1.25
60		1.10	1.15

- Factors for low voltage safe area motors with insulation class F/B ( $\Delta T_{80K}$ )  
 - The breakdown torque should be at least 30 % higher than factors

## 6. Torque

The motors are fitted with squirrel-cage rotors suitable for direct online starting. The values of starting torque and breakdown torque, expressed as a multiple of the rated torque, are given in the performance data. A deviation in the voltage from rated value changes the torques as an approximate function of the square of the voltages.

## 7. Efficiency class

Standard IEC 60034-30 defines uniform efficiency classes, valid for 2, 4, 6 and 8 pole asynchronous motors (50/60 Hz) with output powers of 0.12 kW to 1,000 kW. This standard divides 3-phase induction motors with cage rotor in efficiency classes IE1=standard efficiency, IE2=high efficiency and IE3=premium efficiency. Our motors are labelled with efficiency class and factor on the nameplate.

## 8. Motor protection

The correct selection of protective equipment determines essentially the operation reliability and service life of motors. Current dependent protection and thermal protective devices are available. Fuses do not protect the motor against overloads, they only protect the supply cables or switchboards against short circuits.

## 9. Overload protection (protection relay)

It is recommended to use starters with thermal overload protection. The overloads should be adjusted to the rated current shown on the nameplate. Thermal protective devices (thermistors in windings) see page 385.

## 10. Speed and rotation direction

The rated speed is valid for the rated dates (voltage, frequency). The synchronous speed depends on the line frequency.

The motors are able for operation in both directions. By connection of U1, V1, W1 to L1, L2, L3 the rotation will be to the right if you look at the shaft from the drive-side. Left direction can be easily made by changing of two wires.

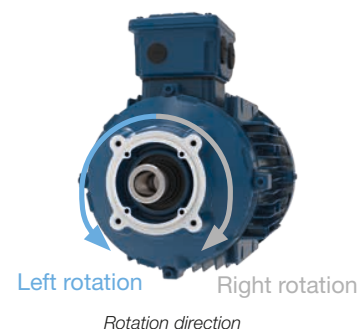

## 11. Cable entry

For all frames, the terminal box can be rotated in 90° increments. Terminal boxes are not delivered with cable glands in standard. Motors are supplied with plastic threaded plugs in the cable entries to maintain the degree of protection during transport and storage. In order to guarantee the degree of protection, cable entries must comply with at least the same degree of protection indicated on the motor nameplate.

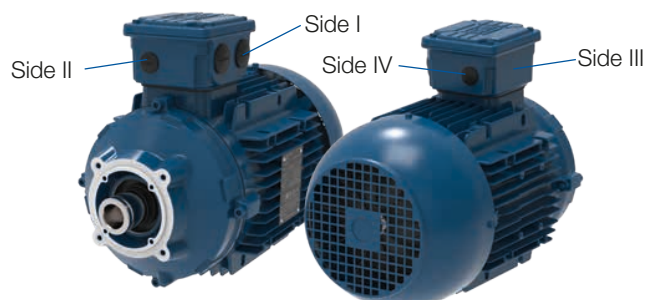

Side designation for cable entries

## 12. Motors for the Ex area according to Directive 2014/34/EU

The modular integral motors can be used in both safe area applications and explosion-proof areas. The motors are certified for category 3, zone 2+22.

Zone 2: II 3G Ex ec IIC T3 Gc  
 Zone 22: II 3D Ex tc IIC T125°C Dc

The protection types in this case are increased safety (Ex ec) and protection by means of housing (Ex tc). The motors can be used in a temperature range of -20 to +40 °C.

If temperatures deviate or additional motor options (brakes, encoders, etc.) are required, please contact us beforehand.

## 13. Cooling

The motors are totally enclosed fan cooled (TEFC) by means of external surface ventilation (IC411, as per IEC 60034-6). Maximum ambient temperature +40 °C. Please check the minimum distance "Y" (see dimension sheets from page 380) between cover and wall by mounting the motor.

### ▪ Integral fans (TEFC, IC411)

Particular attention has been dedicated to the shape in order to reduce noise and improve the efficiency of the motor. Radial construction has been selected to allow rotation in both directions.

### ▪ Fan cover

In treated steel plate, properly profiled to improve efficiency and reduce the noise produced by the fan.

### ▪ Forced ventilation (TEFV, IC416) see also page 403

For special operating conditions, e.g. increased permissible number of operations per hour or variable speed operation, the motors of IEC sizes 63 to 200 can be supplied with forced ventilation by means of a separately fitted fan motor.

## 14. Insulation

The motors in this catalogue comply with the requirements of thermal class F. All windings are impregnated with varnish with a high mechanical strength. The maximum temperature of the insulation is, according to thermal class F, at +155 °C. The motors are utilised at rated values according to thermal class B (+130 °C). Copper wire insulation and the impregnation varnish have a temperature index class F and therefore there is a large margin of safety in addition to high overload capacity. Motors from frame size 160 are equipped with the WISE® insulation system of the new W22 motor range by WEG.

## 15. Noise levels

Noise measurements were taken in accordance with standard IEC 60034-9 (see table to the right).

## 16. Balancing of rotors

Motors comply with vibration strength level "A" according to standard IEC 60034-14. On request, motors may also be balanced according to level "B".

## 17. Shaft ends

Shaft ends of motors in frame sizes 63 up to 132 are equipped with a conical bore and do not have a key, while the frame sizes 160 to 250 have a shaft with closed end keyway. On the non-driven side, modular motors have a system shaft to mount motor modules, such as brakes, encoders, back stops, etc.

## 18. Voltage, current and frequency

In standard execution the motors are delivered with following rated voltages: see chapter 19 (basic connection).

### Special voltages

Motors for special voltages and/or frequencies are available on request.

### Speed and connection

Tolerance of the motor speed according to IEC 60034. Terminal board connection see page 369.

Frame size	Noise level - dB(A), Distance: 1 meter			
	50 Hz		60 Hz	
	4p	6p	4p	6p
63	44	43	48	47
71	43	43	47	47
80	44	43	48	47
90	49	45	51	49
100	53	44	54	53
112	56	52	56	52
132	56	53	58	55
160	61	56	-	-
180	61	56	-	-
200	63	60	-	-
225	63	61	-	-
250	64	61	-	-



## Connection

### ▪ Direct connection

The starting torque in direct connection amounts to 160 to 330 % of the rated torque, depending on power and number of poles. The starting current is about 2.5 to 8 times of the rated current.

### ▪ Star-delta starting

The star-delta (Y-D) starting is an easy way to reduce the starting current and starting torque. Motors can be started with this starting method whenever the supply voltage corresponds to the rated voltage of the motors in delta connections. Up from frame size 112 the standard modular motors are supplied with windings designed for this starting method (e.g. 400 V D / 690 V Y). A Y-D-starting is only possible with delta service connection (this shall be considered when selecting a motor!), as the motor is first Y-connected and is changed over to D-connection after the run-up phase. At Y-D-starting, the starting currents and torques will be reduced to about 1/3 of the values produced in case of direct-online starting. Attention should be paid to the fact that a current impulse is produced when changing over to D-connection.

## 19. Electrical connection

Rated voltages for motor series 11N, 11P (IEC frame sizes 63 to 100)					
Possible connection		Rated power $P_N$	Increased rated power $1.2 \times P_N$	Frequency inverter operation	
	Delta	220 - <b>230</b> - 240 V at 50 Hz 220 - <b>265</b> - 277 V at 60 Hz	254 - 265 - 277 V at 60 Hz		400 V, 87 Hz
	Delta - Delta	110 - <b>115</b> - 120 V at 50 Hz 110 - <b>132</b> - 138 V at 60 Hz	127 - 132 - 138 V at 60 Hz		230 V, 100 Hz
	Star (basic connection)	380 - <b>400</b> - 420 V at 50 Hz 380 - <b>460</b> - 480 V at 60 Hz	440 - 460 - 480 V at 60 Hz		400 V, 100 Hz
	Star - Star	190 - <b>200</b> - 210 V at 50 Hz 190 - <b>230</b> - 240 V at 60 Hz	220 - 230 - 240 V at 60 Hz		460 V, 120 Hz

Rated voltages for motor series 11P and 22P (IEC frame sizes 112 to 250)					
Possible connection		Rated power $P_N$	Increased rated power $1.2 \times P_N$	Frequency inverter operation	
	Delta (basic connection)	380 - <b>400</b> - 420 V at 50 Hz 380 - <b>460</b> - 480 V at 60 Hz	440 - 460 - 480 V at 60 Hz		400 V, 100 Hz
	Delta - Delta	190 - <b>200</b> - 210 V at 50 Hz 190 - <b>230</b> - 240 V at 60 Hz	220 - 230 - 240 V at 60 Hz		
	Star	660 - <b>690</b> - (730) V at 50 Hz 660 - ( <b>796</b> ) - (830) V at 60 Hz	(760) - (796) V at 60 Hz		460 V, 120 Hz
	Star - Star	330 - <b>346</b> - 365 V at 50 Hz 330 - <b>400</b> - 415 V at 60 Hz	380 - 400 - 415 V at 60 Hz		

## Terminal board connection

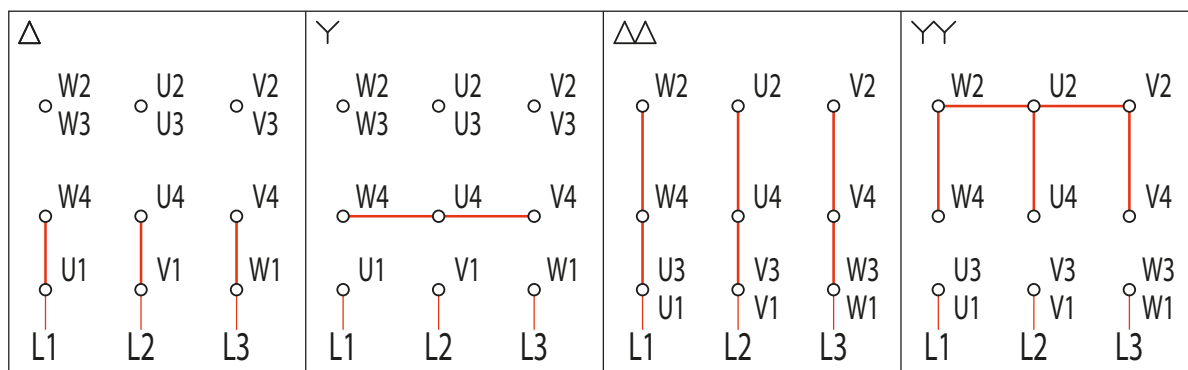

## 20. Variable speed drive application

The stator windings of the motors are wound with class F insulation (class H optional) and are suitable for either DOL starting or - regarding the limits shown in the tabel below - via a variable speed drive.

Rated voltage				
220-240/380-415 V (50 Hz) 400-460 V (60 Hz)				
Motor rated voltage	Voltage spikes	dV/dt *	Rise time *	Time between pulses
	At motor terminals (phase-phase)	At motor terminals (phase-phase)		
$V_{rated} < 460 \text{ V}$	$\leq 1600 \text{ V}$	$\leq 5200 \text{ V}/\mu\text{s}$	$\geq 0.1 \mu\text{s}$	$\geq 6 \mu\text{s}$
$460 \text{ V} \leq V_{rated} < 575 \text{ V}$	$\leq 2000 \text{ V}$	$\leq 6500 \text{ V}/\mu\text{s}$		
$575 \text{ V} \leq V_{rated} \leq 1000 \text{ V}$	$\leq 2400 \text{ V}$	$\leq 7800 \text{ V}/\mu\text{s}$		

\* dV/dt and rise time definition according to NEMA MG1 - part 30

### Notes:

- In order to protect the motor insulation system, the maximum recommended switching frequency is 5 kHz.
- If one or more of the above conditions is not attended, a filter (load reactor or dV/dt filter) must be installed in the output of the VSD.
- General purpose motors with rated voltage greater than 575 V, which at the time of purchase did not have any indication of operation with VSD, are able to withstand the electrical limits set in the table above for rated voltage up to 575 V. If such conditions are not fully satisfied, output filters must be used.
- General purpose motors of the dual voltage type, for example 400/690 V or 380/660 V, which at the time of purchase did not have any indication of operation with VSD, are able to be driven by a VSD in the higher voltage only if the limits set in the table above for rated voltage up to 460 V are fully attended in the application. Otherwise, a load reactor or a dV/dt filter must be installed in the VSD output.



## Electrical basic data

### Notes for electrical basic data

The technical data according to selection tables (starting current, torques, power factor, etc.) are valid for the rated values, that means for the rated voltage and rated frequency.

If the motors are running on higher or lower voltage within the wide range voltage, the stator winding will be utilised according to thermal class F. In these cases a power increase in accordance to a. and b. on page 366 is not possible.

The design of the wide range winding permits supply voltage deviations in the indicated wide range voltage of  $\pm 5\%$  without reduction of the power.

Series	IEC frame size	Type	1	2	3					4	5	6			7	8	9	10	11	12
			$P_N$ [kW]	$n_N$ [min <sup>-1</sup> ]	$I_N$ at 115 V [A]	$I_N$ at 200 V [A]	$I_N$ at 230 V [A]	$I_N$ at 400 V [A]	$I_N$ at 690 V [A]	$\frac{I_A}{I_N}$ at 400 V	IE class	$\eta$ 4/4 [%]	$\eta$ 3/4 [%]	$\eta$ 1/2 [%]	$\cos\phi$	$M_N$ [Nm]	$\frac{M_A}{M_N}$	$\frac{M_K}{M_N}$	$J_{mot}$ [kgm <sup>2</sup> ]	$m$ [kg]

Type	$P_N$ [kW]	at 380 V						at 420 V						Frequency inverter operation						Brake		
		$I_N$ [A]	$\frac{M_A}{M_N}$	$\frac{M_K}{M_N}$	$I_N$ [A]	$\frac{M_A}{M_N}$	$\frac{M_K}{M_N}$	400 V / 87 Hz			400 V / 100 Hz			$M_B$ [Nm]	$J_B$ x10 <sup>-3</sup> [kgm <sup>2</sup> ]	$m$ [kg]						

- 1  $P_N$  = Rated power
- 2  $n_N$  = Rated speed
- 3  $I_N$  = Rated current
- 4  $I_A/I_N$  = Ratio of starting current to rated current
- 5 IE class = Efficiency class
- 6  $\eta$  4/4 (3/4, 1/2) = Efficiency at rated power
- 7  $\cos\phi$  = Power factor
- 8  $M_N$  = Rated torque
- 9  $M_A/M_N$  = Ratio of starting torque to rated torque
- 10  $M_K/M_N$  = Ratio of sweeping torque to rated torque
- 11  $J_{mot}$  = Motor moment of inertia
- 12  $m$  = Weight of the motor
- 13  $M_B$  = Braking torque
- 14  $J_B$  = Brake moment of inertia
- 15  $m$  = Weight of the motor brake



4 Poles, 1500 min<sup>-1</sup>, 50 Hz

Series	IEC frame size	Type	P <sub>N</sub>	n <sub>N</sub>	I <sub>N</sub>	I <sub>N</sub>	I <sub>N</sub>	I <sub>N</sub>	I <sub>N</sub>	I <sub>A</sub>	IE class	η	η	η	cosφ	M <sub>N</sub>	M <sub>A</sub>	M <sub>K</sub>	J <sub>mot</sub>	m
			[kW]	[min <sup>-1</sup> ]	at 115 V [A]	at 200 V [A]	at 230 V [A]	at 400 V [A]	at 690 V [A]	at 400 V [A]		[%]	[%]	[%]		[Nm]	M <sub>A</sub> /M <sub>N</sub>	M <sub>K</sub> /M <sub>N</sub>		
11N	63	11N-63-04E	0.12	1375	1.69	0.97	0.85	0.49	-	3.5	IE1	51.0	47.0	43.0	0.70	0.83	2.0	2.2	0.0003	5.0
		11N-63-04F	0.18	1370	2.16	1.24	1.08	0.62	-	3.5	IE1	58.0	54.0	46.0	0.72	1.26	2.0	2.2	0.0004	5.2
	71	11N-71-04E	0.25	1370	2.87	1.65	1.44	0.83	-	3.7	IE1	61.5	58.0	53.0	0.71	1.74	1.8	1.9	0.0004	6.0
		11N-71-04F	0.37	1365	3.69	2.12	1.84	1.06	-	3.7	IE1	66.0	62.0	58.0	0.76	2.59	2.0	2.0	0.0006	6.8
	80	11N-80-04E	0.55	1415	4.94	2.84	2.47	1.42	-	5.4	IE1	70.0	68.0	63.0	0.80	3.71	2.0	2.8	0.0019	8.8
	11P	80	11P-80-04F	0.75	1430	5.70	3.28	2.85	1.64	-	7.0	IE3	82.5	82.0	80.0	0.80	5.01	3.2	3.4	0.0032
90		11P-90S/L-04E	1.1	1455	8.35	4.80	4.17	2.40	-	7.6	IE3	84.8	84.5	83.0	0.78	7.22	2.5	3.3	0.0055	15.8
		11P-90S/L-04F	1.5	1450	11.2	6.42	5.58	3.21	-	7.4	IE3	85.5	85.0	84.0	0.79	9.88	2.6	3.4	0.0066	17.4
100		11P-100L-04E	2.2	1435	16.3	9.40	8.15	4.70	-	7.6	IE3	86.7	86.5	85.0	0.78	14.6	2.5	3.0	0.0090	27.0
		11P-L100L-04F	3	1440	21.9	12.6	10.9	6.30	-	7.8	IE3	88.0	88.0	87.0	0.78	19.9	3.5	3.7	0.0120	33.6
112		11P-112M-04E	4	1450	-	16.4	-	8.20	4.75	7.0	IE3	89.1	89.1	88.7	0.79	26.4	2.3	3.1	0.0182	34.5
132		11P-132S-04E	5.5	1465	-	20.6	-	10.3	5.97	8.5	IE3	90.7	90.7	90.0	0.85	35.9	2.4	3.4	0.0528	53.4
		11P-L132M-04F	7.5	1465	-	28.4	-	14.2	8.22	8.5	IE3	90.6	90.0	87.5	0.84	48.9	2.5	3.4	0.0638	67.0
		11P-L132M-04G	9.2	1460	-	34.7	-	17.4	10.1	8.5	IE3	91.0	91.0	90.1	0.84	60.2	2.5	3.3	0.0730	72.0
22P		160	22P-160M-04E	11	1470	-	41.8	-	20.9	12.0	7.5	IE3	91.6	91.8	91.1	0.83	71.5	2.8	3.2	0.1191
	22P-160L-04F		15	1465	-	55.8	-	27.9	16.2	7.2	IE3	92.3	92.5	92.2	0.84	97.8	2.8	3.1	0.1534	157
	180	22P-180M-04E	18.5	1470	-	70.2	-	35.1	20.4	7.4	IE3	92.8	92.8	92.2	0.82	120	3.0	3.2	0.1740	171
		22P-180L-04F	22	1470	-	82.1	-	41.0	23.8	7.3	IE3	93.2	93.0	92.3	0.83	143	3.4	3.4	0.2097	192
	200	22P-200L-04E	30	1480	-	114	-	57.1	33.1	7.5	IE3	93.7	93.6	92.9	0.81	194	2.8	3.1	0.3202	250
		22P-200L-04F	37	1480	-	144	-	72.0	41.7	8.3	IE3	93.9	93.5	92.5	0.79	239	3.0	3.3	0.3869	277
	225	22P-225S/M-04F	45	1480	-	162	-	80.9	46.9	7.5	IE3	94.4	94.1	93.7	0.85	291	2.8	3.1	0.6733	414
		22P-225S/M-04G	55	1480	-	205	-	102	59.3	8.3	IE3	94.6	94.0	93.5	0.82	355	3.1	3.4	0.7347	462
	250	22P-250S/M-04F	75	1480	-	262	-	131	75.9	7.8	IE3	95.0	94.8	94.5	0.87	484	2.8	3.3	1.2200	566



Legend see page 371

**4 Poles, 1500 min<sup>-1</sup>, 50 Hz**

Type	P <sub>N</sub> [kW]	at 380 V						at 420 V						Frequency inverter operation						Brake		
		at 380 V			at 420 V			400 V / 87 Hz			400 V / 100 Hz			M <sub>B</sub> [Nm]	J <sub>B</sub> x10 <sup>-3</sup> [kgm <sup>2</sup> ]	m [kg]						
		I <sub>N</sub> [A]	M <sub>A</sub> M <sub>N</sub>	M <sub>K</sub> M <sub>N</sub>	I <sub>N</sub> [A]	M <sub>A</sub> M <sub>N</sub>	M <sub>K</sub> M <sub>N</sub>	P <sub>N</sub> [kW]	n <sub>N</sub> [min <sup>-1</sup> ]	I <sub>N</sub> [A]	P <sub>N</sub> [kW]	n <sub>N</sub> [min <sup>-1</sup> ]	I <sub>N</sub> [A]									
11N-63-04E	0.12	0.51	1.8	2.0	0.46	2.2	2.4	0.21	2393	0.89	0.24	2750	1.02	2 5	0.015 0.015	1.1 1.1						
11N-63-04F	0.18	0.65	1.8	2.0	0.59	2.2	2.4	0.31	2384	1.13	0.36	2740	1.31									
11N-71-04E	0.25	0.87	1.6	1.7	0.79	2.0	2.1	0.44	2384	1.51	0.50	2740	1.73	5 2	0.015 0.015	1.1 1.1						
11N-71-04F	0.37	1.12	1.8	1.8	1.01	2.2	2.2	0.64	2375	1.93	0.74	2730	2.23									
11N-80-04E	0.55	1.49	1.8	2.5	1.35	2.2	3.1	0.96	2462	2.59	1.1	2830	2.98	10 5	0.045 0.015	1.9 1.1						
11P-80-04F	0.75	1.73	2.9	3.1	1.56	3.5	3.7	1.3	2488	2.99	1.5	2860	3.44									
11P-90S/L-04E	1.1	2.53	2.3	3.0	2.29	2.8	3.6	1.9	2532	4.38	2.2	2910	5.04	20 10	0.173 0.045	3.1 1.9						
11P-90S/L-04F	1.5	3.38	2.3	3.1	3.06	2.9	3.7	2.6	2523	5.86	3	2900	6.74									
11P-100L-04E	2.2	4.95	2.3	2.7	4.48	2.8	3.3	3.8	2497	8.56	4.4	2870	9.87	40 20	0.45 0.173	4.6 3.1						
11P-L100L-04F	3	6.63	3.2	3.3	6.00	3.9	4.1	5.2	2506	11.4	6	2880	13.2									
11P-112M-04E	4	8.63	2.1	2.8	7.81	2.5	3.4	-	-	-	8	2900	17.2	60 40	0.86 0.45	6.3 4.6						
11P-132S-04E	5.5	10.8	2.2	3.1	9.81	2.6	3.7	-	-	-	11	2930	21.6	100 60	1.22 0.86	10.0 6.3						
11P-L132M-04F	7.5	14.9	2.3	3.1	13.5	2.8	3.7	-	-	-	15	2930	29.8									
11P-L132M-04G	9.2	18.3	2.3	3.0	16.6	2.8	3.6	-	-	-	18.4	2920	36.5									
22P-160M-04E	11	22.0	2.5	2.9	19.9	3.1	3.5	-	-	-	22	2940	43.9	150 100	2.85 6.65	14.7 10.0						
22P-160L-04F	15	29.4	2.5	2.8	26.6	3.1	3.4	-	-	-	30	2930	58.6									
22P-180M-04E	18.5	36.9	2.7	2.9	33.4	3.3	3.5	-	-	-	37	2940	73.7	250 150	6.65 2.85	21.5 14.7						
22P-180L-04F	22	43.2	3.1	3.1	39.0	3.7	3.7	-	-	-	44	2940	86.1									
22P-200L-04E	30	60.1	2.5	2.8	54.4	3.1	3.4	-	-	-	60	2960	120	400 250	19.5 6.65	35 21.5						
22P-200L-04F	37	75.8	2.7	3.0	68.6	3.3	3.6	-	-	-	74	2960	151									
22P-225S/M-04F	45	85.2	2.5	2.8	77.0	3.1	3.4	-	-	-	90	2960	170	400 250	19.5 6.65	35 21.5						
22P-225S/M-04G	55	107	2.8	3.1	97.1	3.4	3.7	-	-	-	110	2960	214									
22P-250S/M-04F	75	138	2.5	3.0	125	3.1	3.6	-	-	-	150	2960	275	1000	45	73						



Legend see page 371

4 Poles, 1800 min<sup>-1</sup>, 60 Hz

Series	IEC frame size	Type	P <sub>N</sub>	n <sub>N</sub>	I <sub>N</sub>	I <sub>N</sub>	I <sub>N</sub>	I <sub>N</sub>	I <sub>N</sub>	I <sub>A</sub>	IE class	η	η	η	cosφ	M <sub>N</sub>	M <sub>A</sub>	M <sub>K</sub>	J <sub>mot</sub>	m
			[kW]	[min <sup>-1</sup> ]	at 132 V [A]	at 230 V [A]	at 400 V [A]	at 265 V [A]	at 460 V [A]	at 460 V [A]		at 460 V [A]	at 460 V [A]	[%]						
11N	63	11N-63-04E	0.12	1695	1.54	0.88	0.51	0.77	0.44	5.0	IE1	62.0	55.0	42.0	0.55	0.68	3.2	4.2	0.0003	5.0
		11N-63-04F	0.18	1700	1.89	1.09	0.63	0.94	0.54	4.2	IE1	66.0	55.7	47.5	0.63	1.01	2.6	2.7	0.0004	5.2
	71	11N-71-04E	0.25	1700	2.40	1.38	0.80	1.20	0.69	3.7	IE1	68.0	65.0	55.0	0.67	1.41	2.1	2.2	0.0004	6.0
		11N-71-04F	0.37	1685	3.52	2.02	1.17	1.75	1.01	4.7	IE1	70.0	64.0	58.2	0.66	2.10	2.7	2.7	0.0006	6.8
	80	11N-80-04E	0.55	1725	4.29	2.46	1.42	2.14	1.23	6.5	IE1	74.0	71.0	64.9	0.76	3.05	2.5	3.6	0.0019	8.8
	11P	80	11P-80-04F	0.75	1740	5.16	2.96	1.71	2.57	1.48	8.3	IE3	83.5	80.0	78.5	0.76	4.12	3.8	4.3	0.0032
90		11P-90S/L-04E	1.1	1760	7.32	4.20	2.42	3.65	2.10	8.5	IE3	86.5	84.0	80.0	0.76	5.97	2.9	3.9	0.0055	15.8
		11P-90S/L-04F	1.5	1755	9.86	5.66	3.22	4.91	2.83	8.3	IE3	86.5	85.5	82.5	0.77	8.17	3.0	3.8	0.0066	17.4
100		11P-100L-04E	2.2	1745	14.1	8.12	4.66	7.02	4.04	9.0	IE3	89.5	88.0	85.0	0.76	12.0	2.8	3.5	0.0090	27.0
		11P-L100L-04F	3	1740	19.0	10.9	6.27	9.46	5.43	8.6	IE3	89.5	86.5	84.0	0.77	16.5	4.6	4.8	0.0120	33.6
112		11P-112M-04E	4	1755	-	14.6	8.37	-	7.28	8.0	IE3	89.5	89.5	87.5	0.77	21.8	2.5	3.5	0.0182	34.5
132		11P-132S-04E	5.5	1765	-	18.1	10.4	-	9.07	8.9	IE3	91.7	91.0	88.5	0.83	29.8	2.6	4.3	0.0528	53.4
		11P-L132M-04F	7.5	1770	-	24.8	14.3	-	12.4	9.0	IE3	91.7	91.5	91.0	0.83	40.5	2.7	4.3	0.0638	67.0
		11P-L132M-04G	9.2	1765	-	30.7	17.7	-	15.4	9.0	IE3	91.7	91.5	90.4	0.82	49.8	2.6	3.8	0.0730	72.0
22P		160	22P-160M-04E	11	1775	-	36.9	21.2	-	18.4	8.2	IE3	92.4	92.2	91.0	0.81	59.2	3.0	3.7	0.1191
	22P-160L-04F		15	1775	-	49.4	28.4	-	24.7	7.6	IE3	93.0	92.9	92.0	0.82	80.7	2.9	3.5	0.1534	157
	180	22P-180M-04E	18.5	1775	-	61.3	35.2	-	30.6	7.7	IE3	93.6	93.0	92.0	0.81	99.6	3.4	3.6	0.1740	171
		22P-180L-04F	22	1775	-	72.0	41.4	-	36.0	8.5	IE3	93.6	93.2	92.1	0.82	118	3.5	3.8	0.2097	192
	200	22P-200L-04E	30	1780	-	100	57.5	-	50.0	8.3	IE3	94.1	93.7	92.6	0.80	161	2.9	3.5	0.3202	250
		22P-200L-04F	37	1782	-	124	71.5	-	62.2	9.3	IE3	94.5	94.0	93.0	0.79	198	3.5	3.6	0.3869	277
	225	22P-225S/M-04F	45	1782	-	142	81.4	-	70.8	8.6	IE3	95.0	94.5	93.0	0.84	241	3.2	3.5	0.6733	414
		22P-225S/M-04G	55	1785	-	179	103	-	89.3	9.6	IE3	95.4	94.5	93.8	0.81	294	3.7	4.2	0.7347	462
	250	22P-250S/M-04F	75	1780	-	229	132	-	115	8.2	IE3	95.4	95.0	94.1	0.86	403	3.2	4.1	1.2200	566



Legend see page 371

**4 Poles, 1800 min<sup>-1</sup>, 60 Hz**

Type	P <sub>N</sub> [kW]	at 380 V			at 420 V			at 440 V			at 480 V			Frequency inverter operation						Brake		
		I <sub>N</sub> [A]	M <sub>A</sub> M <sub>N</sub>	M <sub>K</sub> M <sub>N</sub>	I <sub>N</sub> [A]	M <sub>A</sub> M <sub>N</sub>	M <sub>K</sub> M <sub>N</sub>	I <sub>N</sub> [A]	M <sub>A</sub> M <sub>N</sub>	M <sub>K</sub> M <sub>N</sub>	I <sub>N</sub> [A]	M <sub>A</sub> M <sub>N</sub>	M <sub>K</sub> M <sub>N</sub>	460 V / 105 Hz			460 V / 120 Hz			M <sub>B</sub> [Nm]	J <sub>B</sub> x10 <sup>-3</sup> [kgm <sup>2</sup> ]	m [kg]
														P <sub>N</sub> [kW]	n <sub>N</sub> [min <sup>-1</sup> ]	I <sub>N</sub> [A]	P <sub>N</sub> [kW]	n <sub>N</sub> [min <sup>-1</sup> ]	I <sub>N</sub> [A]			
11N-63-04E	0.12	0.54	2.2	2.9	0.48	2.7	3.5	0.46	2.9	3.8	0.42	3.5	4.6	0.21	2966	0.81	0.24	3390	0.93	2	0.015	1.1
11N-63-04F	0.18	0.66	1.8	1.8	0.59	2.2	2.3	0.57	2.4	2.5	0.52	2.8	2.9	0.32	2975	0.99	0.36	3400	1.14	5	0.015	1.1
11N-71-04E	0.25	0.83	1.4	1.5	0.75	1.8	1.8	0.72	1.9	2.0	0.66	2.3	2.4	0.44	2975	1.26	0.50	3400	1.45	5	0.015	1.1
11N-71-04F	0.37	1.22	1.8	1.8	1.11	2.3	2.3	1.06	2.5	2.5	0.97	2.9	2.9	0.65	2949	1.84	0.74	3370	2.12	2	0.015	1.1
11N-80-04E	0.55	1.49	1.7	2.5	1.35	2.1	3.0	1.29	2.3	3.3	1.18	2.7	3.9	0.96	3019	2.25	1.1	3450	2.58	10	0.045	1.9
11P-80-04F	0.75	1.79	2.6	2.9	1.62	3.2	3.6	1.55	3.5	3.9	1.42	4.1	4.7	1.3	3045	2.70	1.5	3480	3.11	5	0.015	1.1
11P-90S/L-04E	1.1	2.54	2.0	2.7	2.30	2.4	3.3	2.20	2.7	3.6	2.01	3.2	4.2	1.9	3080	3.83	2.2	3520	4.41	20	0.173	3.1
11P-90S/L-04F	1.5	3.43	2.0	2.6	3.10	2.5	3.2	2.96	2.7	3.5	2.71	3.3	4.1	2.6	3071	5.16	3	3510	5.94	10	0.045	1.9
11P-100L-04E	2.2	4.89	1.9	2.4	4.42	2.3	2.9	4.22	2.6	3.2	3.87	3.0	3.8	3.9	3054	7.37	4.4	3490	8.48	40	0.45	4.6
11P-L100L-04F	3	6.57	3.1	3.3	5.95	3.8	4.0	5.68	4.2	4.4	5.20	5.0	5.2	5.3	3045	9.93	6	3480	11.4	20	0.173	3.1
11P-112M-04E	4	8.81	2.3	3.2	7.97	2.8	3.9	7.61	2.3	3.2	6.98	2.7	3.8	-	-	-	8	3510	15.3	60	0.86	6.3
11P-132S-04E	5.5	10.9	2.3	3.9	9.90	2.9	4.7	9.48	2.4	3.9	8.69	2.8	4.7	-	-	-	11	3530	19.0	40	0.45	4.6
11P-L132M-04F	7.5	15.1	2.4	3.9	13.6	3.0	4.7	13.0	2.5	3.9	11.9	2.9	4.7	-	-	-	15	3540	26.0	100	1.22	10.0
11P-L132M-04G	9.2	18.6	2.3	3.4	16.9	2.9	4.2	16.1	2.4	3.5	14.8	2.8	4.1	-	-	-	18.4	3530	32.3	60	0.86	6.3
22P-160M-04E	11	22.3	2.7	3.3	20.2	3.3	4.1	19.2	2.7	3.4	17.6	3.3	4.0	-	-	-	22	3550	38.6	150	2.85	14.7
22P-160L-04F	15	29.9	2.6	3.2	27.0	3.2	3.9	25.8	2.7	3.2	23.7	3.2	3.8	-	-	-	30	3550	51.9	100	6.65	10.0
22P-180M-04E	18.5	37.1	3.1	3.2	33.5	3.7	4.0	32.0	3.1	3.3	29.3	3.7	3.9	-	-	-	37	3550	64.3	250	6.65	21.5
22P-180L-04F	22	43.6	3.2	3.4	39.4	3.9	4.2	37.6	3.2	3.5	34.5	3.8	4.1	-	-	-	44	3550	75.6	150	2.85	14.7
22P-200L-04E	30	60.5	2.6	3.2	54.8	3.2	3.9	52.3	2.7	3.2	47.9	3.2	3.8	-	-	-	60	3560	105	400	19.5	35
22P-200L-04F	37	75.3	3.2	3.2	68.1	3.9	4.0	65.0	3.2	3.3	59.6	3.8	3.9	-	-	-	74	3564	131	250	6.65	21.5
22P-225S/M-04F	45	85.7	2.9	3.2	77.5	3.5	3.9	74.0	2.9	3.2	67.9	3.5	3.8	-	-	-	90	3564	149	400	19.5	35
22P-225S/M-04G	55	108	3.3	3.8	98.1	4.1	4.6	93.4	3.4	3.8	85.6	4.0	4.6	-	-	-	110	3570	188	250	6.65	21.5
22P-250S/M-04F	75	139	2.9	3.7	126	3.5	4.5	120	2.9	3.8	110	3.5	4.5	-	-	-	150	3560	242	1000	45	73

Legend see page 371





6 Poles, 1000 min<sup>-1</sup>, 50 Hz

Series	IEC frame size	Type	P <sub>N</sub>	n <sub>N</sub>	I <sub>N</sub>	I <sub>N</sub>	I <sub>N</sub>	I <sub>N</sub>	I <sub>N</sub>	I <sub>A</sub>	IE class	η	η	η	cosφ	M <sub>N</sub>	M <sub>A</sub>	M <sub>K</sub>	J <sub>mot</sub>	m
			[kW]	[min <sup>-1</sup> ]	at 115 V [A]	at 200 V [A]	at 230 V [A]	at 400 V [A]	at 690 V [A]	at 400 V [A]		[%]	[%]	[%]		[Nm]	M <sub>A</sub> /M <sub>N</sub>	M <sub>K</sub> /M <sub>N</sub>		
11N	63	11N-63-06F	0.12	890	1.87	1.08	0.94	0.54	-	2.6	IE1	48.0	47.0	43.0	0.67	1.29	1.7	1.6	0.00050	5.4
	71	11N-71-06E	0.18	895	2.89	1.66	1.45	0.83	-	3.5	IE1	54.0	52.0	48.0	0.58	1.92	1.8	2.4	0.00080	7.4
		11N-71-06F	0.25	900	3.83	2.20	1.92	1.10	-	3.5	IE1	57.5	57.0	56.5	0.57	2.65	2.2	2.2	0.00090	8.0
	80	11N-80-06E	0.37	920	4.10	2.36	2.05	1.18	-	3.8	IE1	62.0	60.0	55.0	0.73	3.84	1.7	1.7	0.00190	9.6
		11N-80-06F	0.55	930	5.53	3.18	2.77	1.59	-	4.0	IE1	65.8	65.8	65.0	0.76	5.65	2.0	2.6	0.00300	10.8
11P	90	11P-90S/L-06E	0.75	940	6.71	3.86	3.35	1.93	-	5.2	IE3	79.0	79.0	76.5	0.71	7.62	2.5	2.8	0.00660	17.8
	100	11P-100L-06D	1.1	960	9.74	5.60	4.87	2.80	-	6.0	IE3	81.0	80.0	77.0	0.70	10.9	2.1	3.2	0.01100	21.6
		11P-100L-06E	1.5	950	12.9	7.40	6.45	3.70	-	5.5	IE3	82.5	82.5	81.5	0.71	15.1	2.3	2.8	0.01430	25.4
	112	11P-112M-06E	2.2	960	-	10.4	-	5.22	3.03	6.4	IE3	84.5	84.5	83.0	0.72	21.9	2.4	2.9	0.02570	34.4
	132	11P-132S-06E	3	970	-	13.8	-	6.91	4.01	6.0	IE3	85.8	85.8	85.0	0.73	29.6	1.9	2.5	0.05660	55.0
		11P-132M-06F	4	960	-	18.0	-	8.99	5.21	6.5	IE3	86.8	86.8	86.0	0.74	39.8	2.2	2.5	0.05660	56.0
11P-L132M-06G		5.5	970	-	25.0	-	12.5	7.25	7.3	IE3	88.0	87.0	86.0	0.72	54.2	2.1	2.5	0.07550	71.8	



Legend see page 371

**6 Poles, 1000 min<sup>-1</sup>, 50 Hz**

Type	P <sub>N</sub> [kW]	at 380 V						at 420 V						Frequency inverter operation						Brake		
		at 380 V			at 420 V			400 V / 87 Hz			400 V / 100 Hz			M <sub>B</sub> [Nm]	J <sub>B</sub> x10 <sup>-3</sup> [kgm <sup>2</sup> ]	m [kg]						
		I <sub>N</sub> [A]	$\frac{M_A}{M_N}$	$\frac{M_K}{M_N}$	I <sub>N</sub> [A]	$\frac{M_A}{M_N}$	$\frac{M_K}{M_N}$	P <sub>N</sub> [kW]	n <sub>N</sub> [min <sup>-1</sup> ]	I <sub>N</sub> [A]	P <sub>N</sub> [kW]	n <sub>N</sub> [min <sup>-1</sup> ]	I <sub>N</sub> [A]									
11N-63-06F	0.12	0.56	1.5	1.4	0.51	1.9	1.8	0.21	1549	0.98	0.24	1780	1.13	2 5	0.015 0.015	1.1 1.1						
11N-71-06E	0.18	0.87	1.6	2.2	0.79	2.0	2.6	0.31	1557	1.52	0.36	1790	1.74	5 2	0.015 0.015	1.1 1.1						
11N-71-06F	0.25	1.16	2.0	2.0	1.05	2.4	2.4	0.44	1566	2.02	0.50	1800	2.31									
11N-80-06E	0.37	1.24	1.5	1.5	1.12	1.9	1.9	0.64	1601	2.15	0.74	1840	2.48	10 5	0.045 0.015	1.9 1.1						
11N-80-06F	0.55	1.67	1.8	2.3	1.51	2.2	2.9	0.96	1618	2.91	1.1	1860	3.34									
11P-90S/L-06E	0.75	2.03	2.3	2.5	1.84	2.8	3.1	1.3	1636	3.52	1.5	1880	4.05	20 10	0.173 0.045	3.1 1.9						
11P-100L-06D	1.1	2.95	1.9	2.9	2.67	2.3	3.5	1.9	1670	5.11	2.2	1920	5.88	40 20	0.45 0.173	4.6 3.1						
11P-100L-06E	1.5	3.89	2.1	2.5	3.52	2.5	3.1	2.6	1653	6.77	3.0	1900	7.77									
11P-112M-06E	2.2	5.49	2.2	2.6	4.97	2.6	3.2	-	-	-	4.4	1920	11.0	60 40	0.86 0.45	6.3 4.6						
11P-132S-06E	3.0	7.27	1.7	2.3	6.58	2.1	2.8	-	-	-	6	1940	14.5	100 60	1.22 0.86	10.0 6.3						
11P-132M-06F	4.0	9.46	2.0	2.3	8.56	2.4	2.8	-	-	-	8	1920	18.9									
11P-L132M-06G	5.5	13.2	1.9	2.3	11.90	2.3	2.8	-	-	-	11	1940	26.3									

Legend see page 371



6 Poles, 1200 min<sup>-1</sup>, 60 Hz

Series	IEC frame size	Type	P <sub>N</sub>	n <sub>N</sub>	I <sub>N</sub>	I <sub>N</sub>	I <sub>N</sub>	I <sub>N</sub>	I <sub>N</sub>	$\frac{I_A}{I_N}$	IE class	η	η	η	cosφ	M <sub>N</sub>	$\frac{M_A}{M_N}$	$\frac{M_K}{M_N}$	J <sub>mot</sub>	m
			[kW]	[min <sup>-1</sup> ]	at 132 V [A]	at 230 V [A]	at 400 V [A]	at 265 V [A]	at 460 V [A]	at 460 V [A]		[%]	[%]	[%]		[Nm]				
11N	63	11N-63-06F	0.12	1105	1.67	0.96	0.55	0.83	0.48	2.9	IE1	53.2	50.4	46.6	0.59	1.04	2.0	2.0	0.00050	5.4
	71	11N-71-06E	0.18	1105	2.76	1.58	0.91	1.37	0.79	4.0	IE1	54.9	51.8	45.4	0.52	1.56	2.2	2.9	0.00080	7.4
		11N-71-06F	0.25	1110	3.52	2.02	1.17	1.75	1.01	3.7	IE1	58.5	58.0	57.5	0.53	2.15	2.6	2.6	0.00090	8.0
	80	11N-80-06E	0.37	1130	3.76	2.16	1.25	1.87	1.08	4.5	IE1	63.1	59.9	53.1	0.68	3.13	2.2	2.2	0.00190	9.6
		11N-80-06F	0.55	1140	5.54	3.18	1.84	2.76	1.59	5.0	IE1	67.0	67.0	65.0	0.65	4.57	2.5	3.4	0.00300	10.8
11P	90	11P-90S/L-06E	0.75	1145	5.82	3.34	1.92	2.90	1.66	6.2	IE3	82.5	80.0	77.0	0.69	6.26	2.9	3.4	0.00660	17.8
	100	11P-100L-06D	1.1	1165	8.22	4.72	2.73	4.10	2.36	7.9	IE3	87.5	81.0	76.0	0.67	9.02	2.4	3.8	0.01100	21.6
		11P-100L-06E	1.5	1155	11.0	6.30	3.63	5.48	3.14	6.3	IE2	86.5	85.5	82.5	0.69	12.4	2.5	3.2	0.01430	25.4
	112	11P-112M-06E	2.2	1165	-	8.88	5.11	-	4.44	7.6	IE2	87.5	85.5	82.5	0.71	18.0	2.6	3.4	0.02570	34.4
	132	11P-132S-06E	3	1165	-	12.0	6.91	-	6.00	6.3	IE3	89.5	88.5	85.5	0.70	24.6	1.8	2.9	0.05660	55.0
		11P-132M-06F	4	1165	-	15.8	9.09	-	7.90	6.6	IE3	89.5	88.5	85.5	0.71	32.8	1.9	3.0	0.05660	56.0
11P-L132M-06G		5.5	1175	-	21.6	12.4	-	10.8	8.0	IE3	91.0	88.5	85.5	0.70	44.7	2.2	2.8	0.07550	71.8	



Legend see page 371

**6 Poles, 1200 min<sup>-1</sup>, 60 Hz**

Type	P <sub>N</sub> [kW]	at 380 V			at 420 V			at 440 V			at 480 V			Frequency inverter operation						Brake		
		I <sub>N</sub> [A]	$\frac{M_A}{M_N}$	$\frac{M_K}{M_N}$	I <sub>N</sub> [A]	$\frac{M_A}{M_N}$	$\frac{M_K}{M_N}$	I <sub>N</sub> [A]	$\frac{M_A}{M_N}$	$\frac{M_K}{M_N}$	I <sub>N</sub> [A]	$\frac{M_A}{M_N}$	$\frac{M_K}{M_N}$	460 V / 105 Hz			460 V / 120 Hz			M <sub>B</sub> [Nm]	J <sub>B</sub> x10 <sup>-3</sup> [kgm <sup>2</sup> ]	m [kg]
														P <sub>N</sub> [kW]	n <sub>N</sub> [min <sup>-1</sup> ]	I <sub>N</sub> [A]	P <sub>N</sub> [kW]	n <sub>N</sub> [min <sup>-1</sup> ]	I <sub>N</sub> [A]			
11N-63-06F	0.12	0.58	1.4	1.4	0.52	1.7	1.7	0.50	1.8	1.8	0.46	2.2	2.2	0.21	1934	0.87	0.24	2210	1.00	2 5	0.015 0.015	1.1 1.1
11N-71-06E	0.18	0.95	1.5	2.0	0.86	1.8	2.4	0.82	2.0	2.7	0.75	2.4	3.2	0.32	1934	1.44	0.36	2210	1.65	5 2	0.015 0.015	1.1 1.1
11N-71-06F	0.25	1.22	1.8	1.8	1.11	2.2	2.2	1.06	2.4	2.4	0.97	2.8	2.8	0.44	1943	1.84	0.50	2220	2.12			
11N-80-06E	0.37	1.31	1.5	1.5	1.18	1.8	1.8	1.13	2.0	2.0	1.04	2.4	2.4	0.65	1978	1.96	0.74	2260	2.27	10 5	0.045 0.015	1.9 1.1
11N-80-06F	0.55	1.92	1.7	2.3	1.74	2.1	2.8	1.66	2.3	3.1	1.52	2.7	3.7	0.96	1995	2.90	1.1	2280	3.34			
11P-90S/L-06E	0.75	2.01	2.0	2.3	1.82	2.4	2.8	1.74	2.7	3.1	1.59	3.2	3.7	1.31	2004	3.05	1.5	2290	3.49	20 10	0.173 0.045	3.1 1.9
11P-100L-06D	1.1	2.86	1.6	2.6	2.58	2.0	3.2	2.47	2.2	3.5	2.26	2.6	4.1	1.93	2039	4.31	2.2	2330	4.96	40 20	0.45 0.173	4.6 3.1
11P-100L-06E	1.5	3.80	1.7	2.2	3.44	2.1	2.7	3.28	2.3	2.9	3.01	2.7	3.5	2.63	2021	5.75	3	2310	6.59			
11P-112M-06E	2.2	5.38	2.3	3.1	4.87	2.9	3.7	4.64	2.4	3.1	4.26	2.8	3.7	-	-	-	4.4	2330	9.32	60 40	0.86 0.45	6.3 4.6
11P-132S-06E	3	7.27	1.6	2.6	6.58	2.0	3.2	6.27	1.6	2.7	5.75	2.0	3.2	-	-	-	6	2330	12.6	100 60	1.22 0.86	10.0 6.3
11P-132M-06F	4	9.57	1.7	2.7	8.66	2.1	3.3	8.26	1.7	2.7	7.57	2.1	3.3	-	-	-	8	2330	16.6			
11P-L132M-06G	5.5	13.1	2.0	2.5	11.8	2.4	3.1	11.3	2.0	2.6	10.4	2.4	3.0	-	-	-	11	2350	22.7			

Legend see page 371



# Dimension sheets

## Integral motor frame sizes 63 - 132

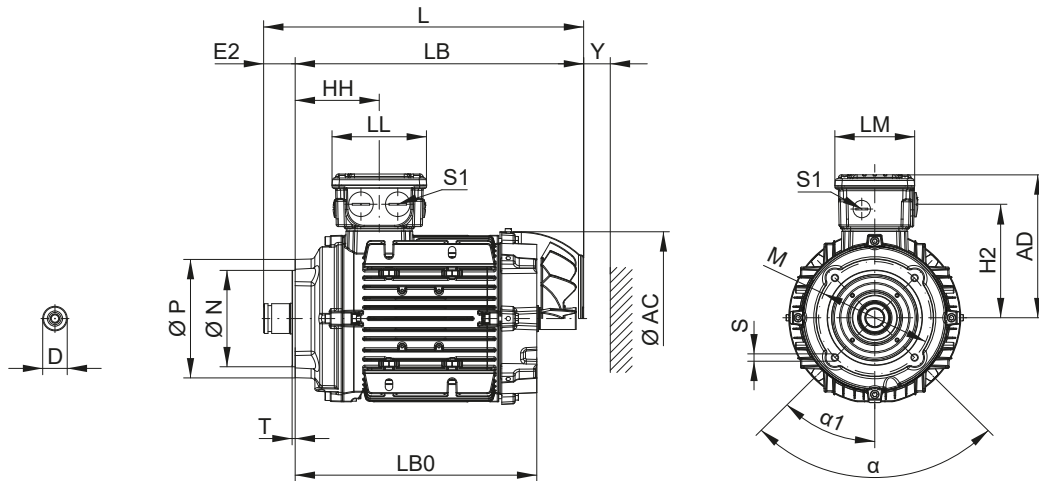

M

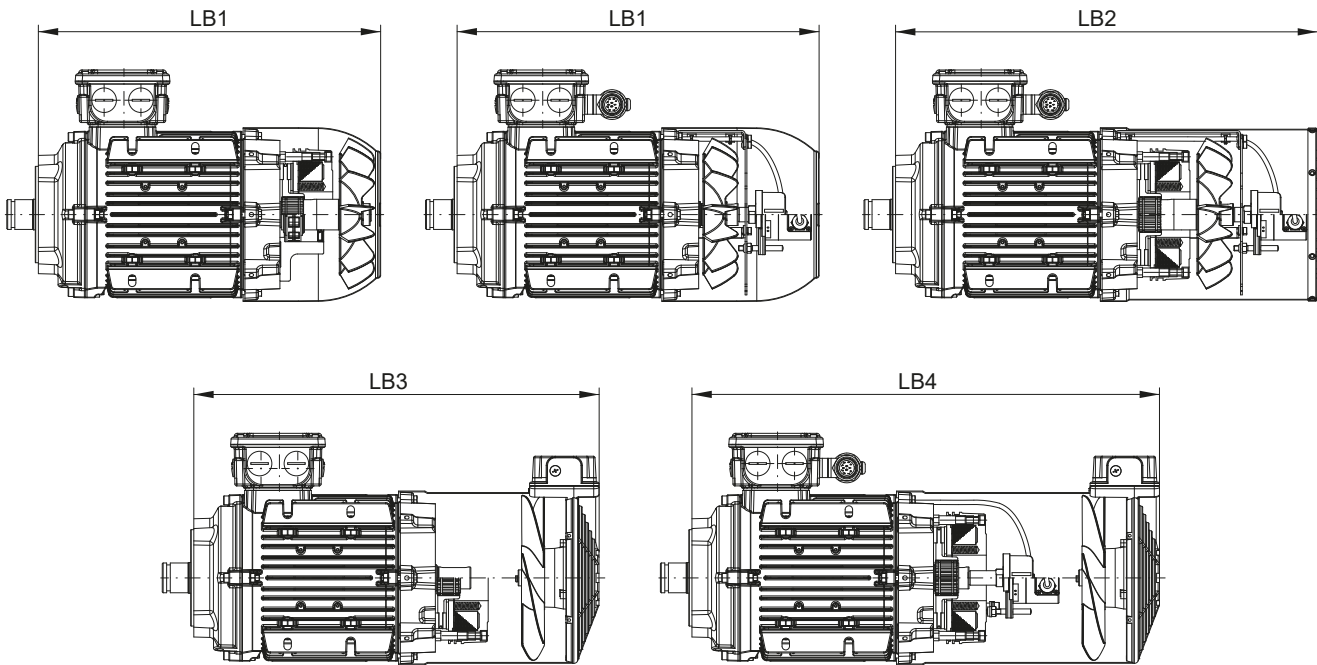

Description of the dimensions L, LB, LB0,... see page 384

Tolerances		
Dimension name	ISO tolerance DIN EN ISO 286-2	
D	≤ Ø 30 mm	j6
	> Ø 30 mm to Ø 50 mm	k6
	> Ø 50 mm	m6
N	≤ Ø 250 mm	j6
	> Ø 250 mm	h6

Dimension tolerances		
Dimension name	Dimensions	Permissible deviation
M	up to 200 mm	± 0.25 mm
	more than 200 up to 500 mm	± 0.5 mm
	ore than 500 mm	± 1.0 mm

Dimensions in mm. Motor dimensions are typical values.  
Subject to change.



IEC frame size	63	71	80	90	100	L100	112	132	L132
AC	126	141	159	178	199	199	221	261	261
AD	125	133	142	152	162	162	180	200	200
D	16	19	24	24	34	34	34	42	42
E2	26	26	26	26	26	26	36	36	36
HH	83	91	88	88	107	107	117	122	122
H2	91	99	108	118	128	128	144	164	164
LL	108	108	108	108	108	108	137	137	137
LM	92	92	92	92	92	92	118	118	118
M	100	100	100	100	100	100	130	130	130
N	80	80	80	80	80	80	110	110	110
P	94	94	94	94	94	94	135	135	135
S	M6	M6	M6	M6	M6	M6	M8	M8	M8
S1	2 x M25 x 1.5 + 2 x M16 x 1.5					2 x M32 x 1.5 + 2 x M16 x 1.5			
T	3	3	3	3	3	3	4	4	4
Y	25	26	30	33	36	36	41	50	50
$\alpha$	4 x 90°	4 x 90°	4 x 90°	4 x 90°	4 x 90°	4 x 90°	4 x 90°	4 x 90°	4 x 90°
$\alpha_1$	45°	45°	45°	45°	45°	45°	45°	45°	45°
L	230	264	272	314	364	402	384	449	487
LB	204	238	246	288	338	376	348	413	451
LB0	173	196	205	242	285	323	290	359	397
LB1	248	287	304	361	422	460	435	531	569
LB2	-	358	381	437	500	538	511	614	652
LB3	322	347	365	422	476	514	493	598	636
LB4	392	417	435	485	532	570	549	650	688



Integral motor frame sizes 160 to 250

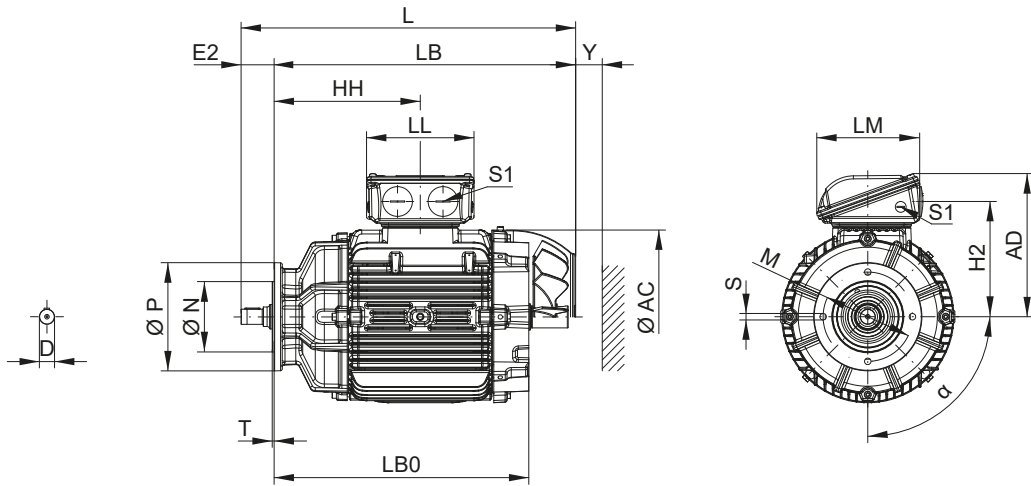

M

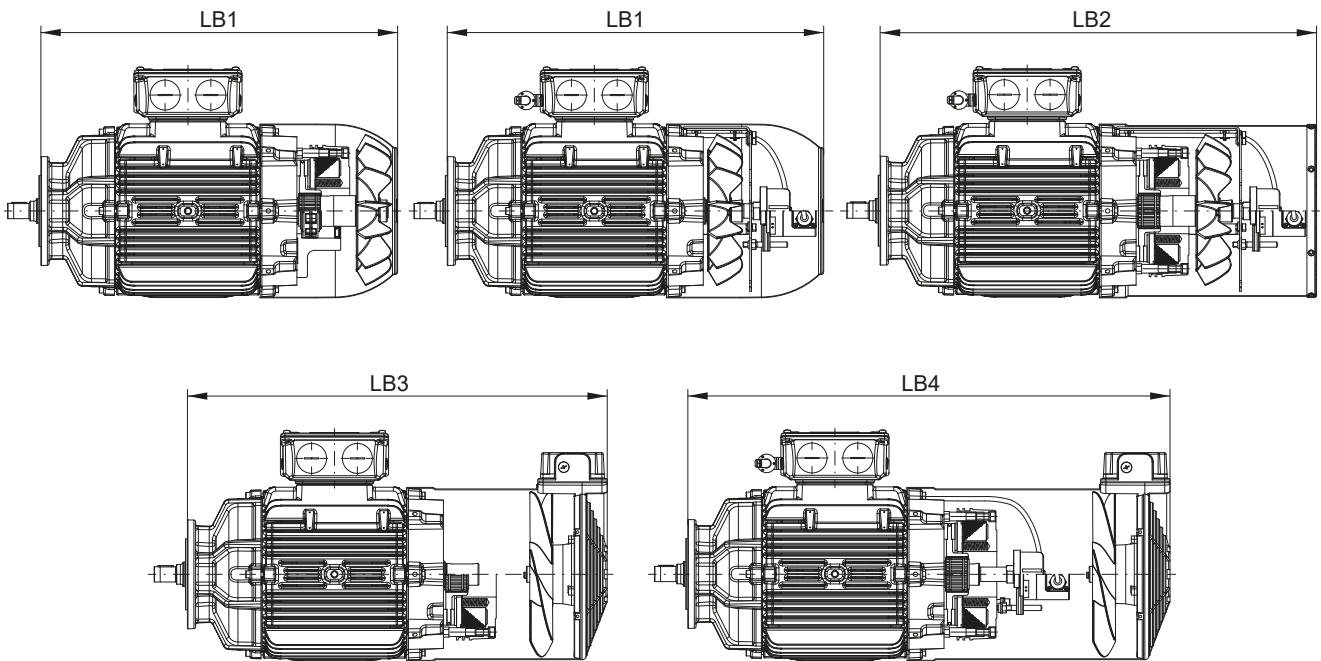

Description of the dimensions L, LB, LB0,... see page 384

Tolerances		
Dimension name	ISO tolerance DIN EN ISO 286-2	
D	$\geq \varnothing 28 \text{ mm}$	n6
N	$\leq \varnothing 250 \text{ mm}$	j6
	$> \varnothing 250 \text{ mm}$	h6

Dimension tolerances		
Dimension name	Dimensions	Permissible deviation
M	up to 200 mm	$\pm 0.25 \text{ mm}$
	more than 200 up to 500 mm	$\pm 0.5 \text{ mm}$
	more than 500 mm	$\pm 1.0 \text{ mm}$

Dimensions in mm. Motor dimensions are typical values. Subject to change.

IEC frame size	160M					160L				
Motor flange	FR-200	FR-250	FR-300	FR-400	FR-550	FR-200	FR-250	FR-300	FR-400	FR-550
AC	318					318				
AD	266					266				
D	28					28				
E2	61	66	71	84	100	61	66	71	84	100
HH	270	265	260	257	241	270	265	260	257	241
H2	213					213				
LL	199					199				
LM	190					190				
M	165	215	265	300	400	165	215	265	300	400
N	130	180	230	300	450	130	180	230	300	450
P	200	250	300	400	550	200	250	300	400	550
S	12	15	15	19	19	12	15	15	19	19
S1	2 x M40 x 1.5 + 2 x M16 x 1.5					2 x M40 x 1.5 + 2 x M16 x 1.5				
T	3,5	4	4	5	5	3,5	4	4	5	5
Y	65					65				
α	4 x 90°					4 x 90°				
L	606					650				
LB	545	540	535	522	506	589	584	579	566	550
LB0	480	475	470	457	441	524	519	514	501	485
LB1	669	664	659	646	630	713	708	703	690	674
LB2	747	742	737	724	708	791	786	781	768	752
LB3	757	752	747	734	718	801	796	791	778	762
LB4	823	818	813	800	784	867	862	857	844	828

IEC frame size	180M				180L			
Motor flange	FR-250	FR-300	FR-400	FR-550	FR-250	FR-300	FR-400	FR-550
AC	347				347			
AD	281				281			
D	32				32			
E2	66	71	84	100	66	71	84	100
HH	303	298	285	269	303	298	285	269
H2	228				228			
LL	199				199			
LM	190				190			
M	215	265	300	400	215	265	300	400
N	180	230	300	450	180	230	300	450
P	250	300	400	550	250	300	400	550
S	15	15	19	19	15	15	19	19
S1	2 x M40 x 1.5 + 2 x M16 x 1.5				2 x M40 x 1.5 + 2 x M16 x 1.5			
T	4	4	5	5	4	4	5	5
Y	68				68			
α	4 x 90°				4 x 90°			
L	674				712			
LB	608	603	590	574	646	641	628	612
LB0	531	526	513	497	569	564	551	535
LB1	726	721	708	692	764	759	746	730
LB2	839	834	821	805	877	872	859	843
LB3	828	823	810	794	866	861	848	832
LB4	893	888	875	859	931	926	913	897

IEC frame size	200L			225S/M		250S/M
Motor flange	FR-300	FR-400	FR-550	FR-400	FR-550	FR-550
AC	386			453		482
AD	317			385		403
D	38			38		48
E2	71	84	100	84	100	100
HH	348	335	319	286	270	261
H2	260			304		321
LL	230			269		268
LM	218			286		286
M	265	300	400	300	400	400
N	230	300	450	300	450	450
P	300	400	550	400	550	550
S	15	19	19	19	19	19
S1	2 x M50 x 1.5 + 2 x M16 x 1.5			2 x M50 x 1.5 + 2 x M16 x 1.5		2 x M63 x 1.5 + 2 x M16 x 1.5
T	4	5	5	5	5	5
Y	78			85		85
α	4 x 90°			8 x 45°		8 x 45°
L	804			912		951
LB	733	720	704	828	812	851
LB0	629	616	600	714	698	737
LB1	859	846	830	946	930	969
LB2	977	964	948	1062	1046	1085
LB3	929	916	900	1100	1084	1123
LB4	1009	996	980	1100	1084	1123



Length description motor modules

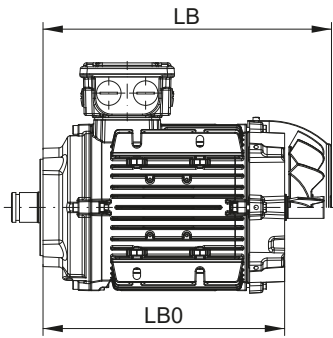

**LB** Self ventilated  
**LB0** Non-ventilated

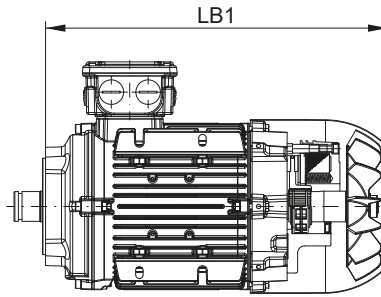

**LB1** Self ventilated with brake or back stop type RSM

M

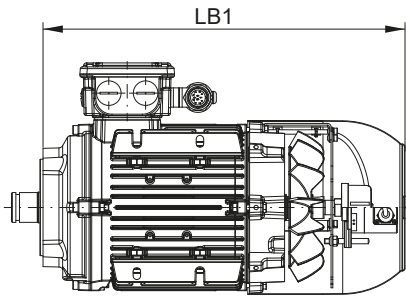

**LB1** Self ventilated with standard encoder, SSI multiturn encoder or resolver

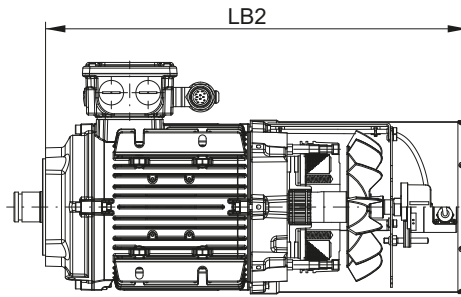

**LB2** Self ventilated with brake and standard encoder, SSI multiturn encoder or resolver

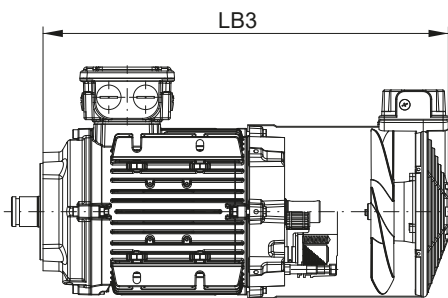

**LB3** Forced ventilation with or without brake

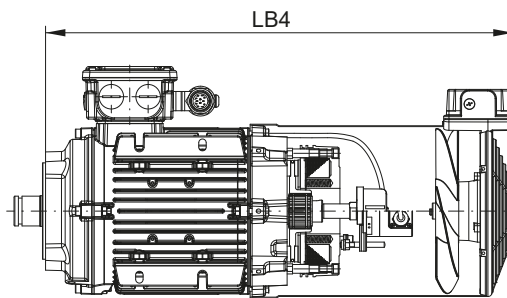

**LB4** Forced ventilation with/without brake and standard encoder, SSI multiturn encoder or resolver

## Motor modules

### High / Low temperature execution

<b>HT</b>	High temperature execution
<b>LT</b>	Low temperature execution

To ensure steady operation even at increased or very low ambient temperatures, we offer specially adjusted motor executions with more resistant components.

### Temperature control

<b>TH</b>	Bimetal switch for switch off
<b>2TH</b>	Bimetal switch for warning and switch off
<b>TF</b>	PTC thermistor for switch off
<b>2TF</b>	PTC thermistor for warning and switch off
<b>KTY</b>	Temperature sensor

In the standard version, the motors are designed with motor protection in the motor winding. In order to protect the winding of a three-phase induction motor against thermal overloads, resulting for example from overloading and operation with only two phases, one of the following devices can be provided:

#### TH - Bimetal switch „NC contact“ (+155 °C)

The contact is normally closed (NC); the disc opens when the winding's temperature reaches limits dangerous for the insulation system. When a limit temperature is reached, these bimetal switches (NC contacts) can deactivate an auxiliary circuit. The circuit can only be reclosed following a considerable fall in temperature. When the motor current rises quickly (e.g. with a locked rotor), these switches are not suitable due to their large thermal time constants.

#### TF - PTC thermistor (+155 °C)

The most comprehensive protection against thermal overloading caused in starting against heavy masses, heavy alternating load and high frequency starting resp. brake operation or high ambient temperatures of the motor is provided by PTC thermistors installed in the motor winding.

The sensors are temperature sensitive resistors (PTC) which change value almost instantaneously at their response temperature. The switch off level corresponds to the thermal class of the insulation. This characteristic is used in combination with tripping devices (on request) to monitor the temperature of the motor. For warning purposes additional bimetal switches or PTC thermistors with lower switch off temperature can be fitted. These correspond to the key **2TH** and **2TF**.

#### KTY - Temperature sensor

This sensor is a semiconductor that changes its resistance depending on temperature in accordance with a defined characteristic. The evaluation is made by an extra tripping device (on request). The temperature sensor is embedded in the winding head of the motor in the same manner as a PTC thermistor. Evaluation is performed, for example, in the frequency inverter.

### Anti-condensation heating

<b>SH</b>	Anti-condensation heating
-----------	---------------------------

Windings of motors, which are operating at conditions of extreme temperature changes or extreme climatic conditions, are endangered of condensation water. The built in anti-condensation heating warms up the motor windings after switching off and prevents the motor inside from condensation water.

**During motor operation the anti-condensation heating must not be switched on. The limit temperature of the winding (+155 °C in thermal class F) must not be exceeded! Temperature control is advisable!**

IEC frame size	Heating performance [W]
71	13
80	25
90	
100	
112	50
132	
160	
180	75
200	
225	
250	100

The anti-condensation heating must be supplied with a separate voltage.

Supply voltage: 230 V (1~) - Voltage range for IEC frame sizes: 71 to 200: 220 - 240 V, 50/60 Hz

## Climatic protection

<b>K1</b>	Humidity protection
<b>K2</b>	Corrosion protection

The following standardised climatic protection executions are available for motors exposed to extreme climatic conditions:

### K1 - Humidity protection

Humid warm climate or humid variable climate with max. relative air humidity of 92 %, also for areas on the seaside

### K2 - Corrosion protection

Relative air humidity of more than 92 % (extreme formation of condensation water), furthermore against chemically aggressive gases and vapours of increased concentration

## Drain

<b>KB</b>	Drain
-----------	-------

In cases of increased air humidity, periodic duty, installation in the open air or when subject to extreme climatic conditions, the motors are endangered by the formation of condensation. The endshields have holes for drainage of water that may condense inside the frame. These holes are supplied with rubber drain plugs, which leave the factory in closed position and must be opened periodically to allow the exit of condensed water.

**To determine the correct position of the hole the exact mounting position of the motor must be defined.**

# M

## Terminal box designs

<b>MIP</b>	Multipin box
<b>MIG..</b>	MIG - connect systems

### MIP - Multipin box

IEC frame sizes: 63 to 250

This extended terminal box was designed to permit additional options, such as brakes, incremental encoders, thermal elements, anti-condensation heating and the like, to be connected in an orderly fashion in the box.

The terminal box can be equipped with up to 22 sockets, including a brake rectifier. The terminal used are two-wire terminals fitted with cage clamp connectors. These are suitable for single-wire, multi-wire and fine-wire lines with diameters up to 4 mm<sup>2</sup>.

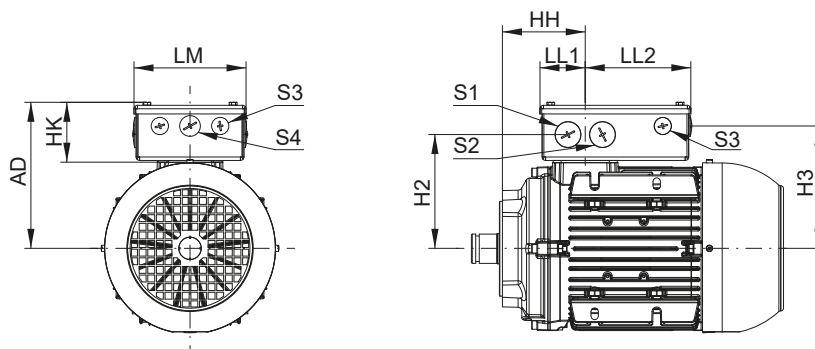

IEC frame size	MIP box												
	AD	HH	HK	H2	H3	LM	LL1	LL2	S1	S2	S3	S4	
63	132	90	69	95	99	130	52	122	2xM25	2xM25	4xM16	1xM20	
71	140	99	69	103	107	130	52	122	2xM25	2xM25	4xM16	1xM20	
80	149	95	69	112	116	130	52	122	2xM25	2xM25	4xM16	1xM20	
90	159	96	69	122	126	130	52	122	2xM25	2xM25	4xM16	1xM20	
100	169	109	69	132	136	130	52	122	2xM25	2xM25	4xM16	1xM20	
112	182	130	70	144	154	140	68	138	2xM32	2xM32	4xM16	1xM25	
132	202	123	70	164	174	140	68	138	2xM32	2xM32	4xM16	1xM25	
160	FR-200	269	104	211	220	205	105	171	2xM50	2xM40	4xM16	1xM25	
	FR-250												270
	FR-300												265
	FR-400												260
180	FR-250	284	104	231	240	205	105	171	2xM50	2xM40	4xM16	1xM25	
	FR-300												257
	FR-400												241
	FR-550												303
200	FR-300	300	104	250	256	205	105	177	2xM50	2xM40	4xM16	1xM25	
	FR-400												298
	FR-550												285
	FR-300												269
225	FR-400	344	104	289	295	205	105	177	2xM50	2xM40	4xM16	1xM25	
	FR-550												348
250	FR-550	361	104	306	312	205	105	177	2xM50	2xM40	4xM16	1xM25	

Dimensions in mm

### MIG - connect system

Models: MIG10B, MIG16, MIG40, MIG10-FL  
IEC frame sizes: 63 to 180 (MIG10-FL up to 250)

The MIG (Multiplug) - connect system is a standardised distributed connection system. It is used for the integration of power and control cabling into a single motor connector. The plug is assembled in-house and replaces the terminal box.

#### Most important advantages:

- Quick installation and service at site
- Avoiding wiring faults
- Motor replacement without electrical manipulation

For motor frame sizes 63 to 180 three MIG types of different power ratings are used. For each MIG model mating connectors are available:

#### MIG10B:

With 18 PINs and ground this most compact plug enables connection to motors up to a rated current of 10 A with voltages up to 400/690 V and protection degrees up to IP67. Beside the power wires a variety of auxiliary wires can be connected as well.

#### MIG16:

This MIG for mid-sized motors supports a maximum current of 16 A at 500 V with 10 PINs in total. In case a wider variety of auxiliary PINs is necessary a mixed holding can be offered (6 PINs - 16 A; 12 PINs - auxiliary).

#### MIG40:

To achieve all contacts to be connected with one plug a mixed holding of PINs has to be used in this case. 6 PINs for 40 A at 400/690 V together with 12 PINs auxiliary guarantees full contactability.

For motor frame sizes 63 to 250 with forced ventilation the following MIG type is available:

#### MIG10-FL:

On demand this MIG can replace the normal forced ventilation connection. Thereby this motor module has all advantages of a MIG - connect plug system. The plug is equipped with 3 PINs and grounding and can be mounted on every forced ventilation size.



MIG40 execution

### MIG - connect system overview table

IEC frame size		63	71	80	90	100	112	132	160	180
400 V, 50 Hz	4p	10B	10B	10B	10B	10B	16	16	40	40
	6p	10B	10B	10B	10B	10B	16	16	40	40
230 V, 50 Hz	4p	10B	10B	10B	10B	16	-	-	-	-
	6p	10B	10B	10B	10B	16	-	-	-	-
400 V, 100 Hz	4p	10B	10B	10B	10B	16	40	40	-	-
	6p	10B	10B	10B	10B	10B	16	40	-	-
460 V, 60 Hz	4p	10B	10B	10B	10B	10B	16	16	40	40
	6p	10B	10B	10B	10B	10B	16	16	40	40
460 V, 120 Hz	4p	10B	10B	10B	10B	16	16	40	-	-
	6p	10B	10B	10B	10B	10B	16	40	-	-

#### PIN assignment MIG10B

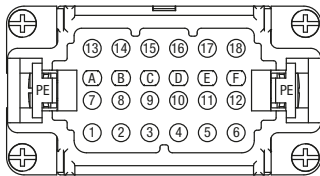

PIN	Assignment
PE	Grounding terminal
1	Winding connection U1
2	Winding connection V1
3	Winding connection W1
4*	Bimetal release 1 TH1
5	Brake heating tape
6	Anti-condensation heating
7	Winding connection W4
8	Winding connection U4
9	Winding connection V4
10*	Bimetal release 1 TH1
11	Brake heating tape
12	Anti-condensation heating

PIN	Assignment
13	Brake
14	Brake
15	Brake microswitch
16	Brake microswitch
17*	Bimetal release 2 TH2
18*	Bimetal release 2 TH2
*alternatively	
4	PTC thermistor 1 TF1
10	PTC thermistor 1 TF1
17	PTC thermistor 2 TF2
17	Resistance thermometer KTY1
18	PTC thermistor 2 TF2
18	Resistance thermometer KTY 1

#### PIN assignment MIG16

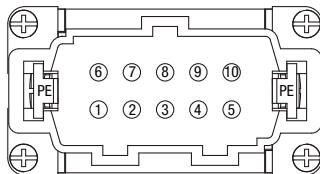

PIN	Assignment
PE	Grounding terminal
1	Winding connection U1
2	Winding connection V1
3	Winding connection W1
4*	Brake
5*	Brake
6	Winding connection W4
7	Winding connection U4

PIN	Assignment
8	Winding connection V4
9*	Temperature sensor 1
10*	Temperature sensor 1
*alternatively	
9	Anti-condensation heating
10	Anti-condensation heating
4	Temperature sensor 2
5	Temperature sensor 2

#### PIN assignment MIG40

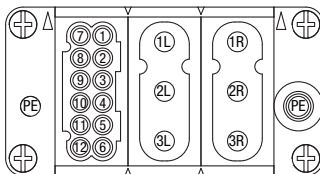

PIN	Assignment
PE	Grounding terminal
1R	Winding connection U1
2R	Winding connection V1
3R	Winding connection W1
1L	Winding connection W4
2L	Winding connection U4
3L	Winding connection V4
1	Brake
2	Temperature sensor 1
3	Temperature sensor 2

PIN	Assignment
4	Temperature sensor 3
5	Anti-condensation heating
6	
7	Brake
8	Temperature sensor 1
9	Temperature sensor 2
10	Temperature sensor 3
11	Anti-condensation heating
12	

#### PIN assignment MIG10-FL

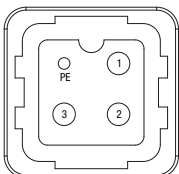

PIN	Assignment
PE	Grounding terminal
1	Power connection L1
2	Power connection L2
3	Power connection L3

M



### Dimension sheet MIG10B, MIG16, MIG40

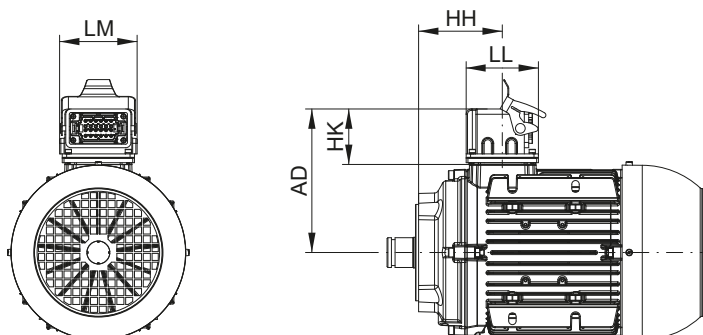

IEC frame size	MIG - connect system						
	MIG Type	AD	HH	HK	LL	LM	
63	10B	124	90	61	82	86	
71	10B	132	99	61	82	86	
80	10B	141	95	61	82	86	
90	10B	151	96	61	82	86	
100	10B / 16	161	109	61	82	86	
112	16 / 40	173	130	61	82	86	
132	16 / 40	193	123	61	82	86	
160	FR-200	40	226	270	61	82	86
	FR-250			265			
	FR-300			260			
	FR-400			257			
	FR-550			241			
180	FR-250	40	241	303	61	82	86
	FR-300			298			
	FR-400			285			
	FR-550			269			

Dimensions in mm

### Dimension sheet MIG10-FL

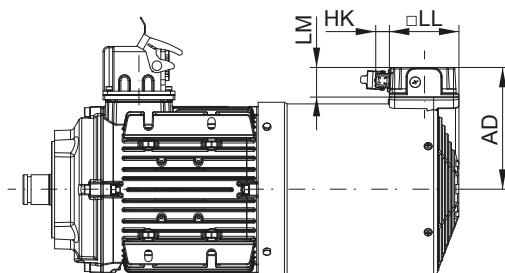

IEC frame size	MIG10-FL			
	AD	HK	□LL	LM
63	118	28	107	32
71	124			
80	134			
90	143			
100	152			
112	164			
132	185			
160	211			
180	211			
200	211			
225	211			
250	211			

Dimensions in mm



### Brake system and Back stop

<b>BR..</b>	Spring loaded brake
<b>BBRHGD..</b>	Double spring loaded brake
<b>BRGH..</b>	Totally closed spring loaded brake (Heavy Duty)
<b>KKM</b>	Back stop (frame sizes 63 to 90)
<b>RSM</b>	Back stop (frame sizes 100 to 250)

The mounted spring loaded brake is a single-disc brake with two friction surfaces. It is released electromagnetically and brakes by spring pressure, when the brake is de-energised. The DC-brake coil is supplied from a rectifier which is located in the motor terminal box and will be delivered as standard for AC-side connection.

#### Product information

- Voltages: 195 V DC (standard), 24 V DC (optional) and 102 V DC (special execution)
- All bare parts corrosion protected
- Short switching times
- Large reserve for abrasion
- Designed for 100 % duty cycle and max. admissible temperature limit of +145 °C
- Degree of protection IP55 (standard)

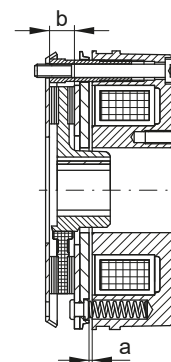

a air gap  
b brake lining thickness

On motors with brake-endshield on the non-driven side subsequent installation of brakes is possible (brake-motor-set available).

### Function and adjustment (see illustration below)

When the brake is de-energised, the springs are pressing the armature disc (9) against the brake disc (7) and the friction plate (5). The motor shaft (3) is braked via the brake disc (7) and the gear hub (6). When the brake is energised, a magnetic field is built up and the armature disc (9) is pulled against the magnetic case with the coil (10). When the motor is running, the brake disc (7) can rotate freely from the brake surfaces. In the case of power failure, the brake functions automatically by spring force. A manual release (11) is optionally available (subsequent assembling is also possible).

### Braking torque adjustment

At delivering, the brakes and the brake motors are adjusted to the brake torque  $M_B$ . Brake torque reduction is done by removing of springs. Reduced brake torque see page 391.

### Maintenance

Due to abrasion of the friction linings (7) the air gap "a" (see page 389) between magnetic case (10) and armature disc (9) expands. It is necessary to check and readjust the air gap in certain intervals or replace the brake disc (7).

### Readjustment of the air gap

First of all the three fixing screws (13) must be loosened half a turn. Now the sleeve screws (8) can be screwed into the magnetic case (10) by turning counter-clockwise. By turning the three fixing screws (13) clockwise, the magnetic case (10) can be moved in direction to the armature disc (9), as long as the nominal air gap  $a_{normal}$  (see table on page 392) is obtained. Now the three sleeve screws (8) will be unscrewed clockwise from the magnetic case (10) and the fixing screws (13) will be fixed. Please check the air gap "a" with a feeler gauge, if it is symmetrical and adjust it if necessary.

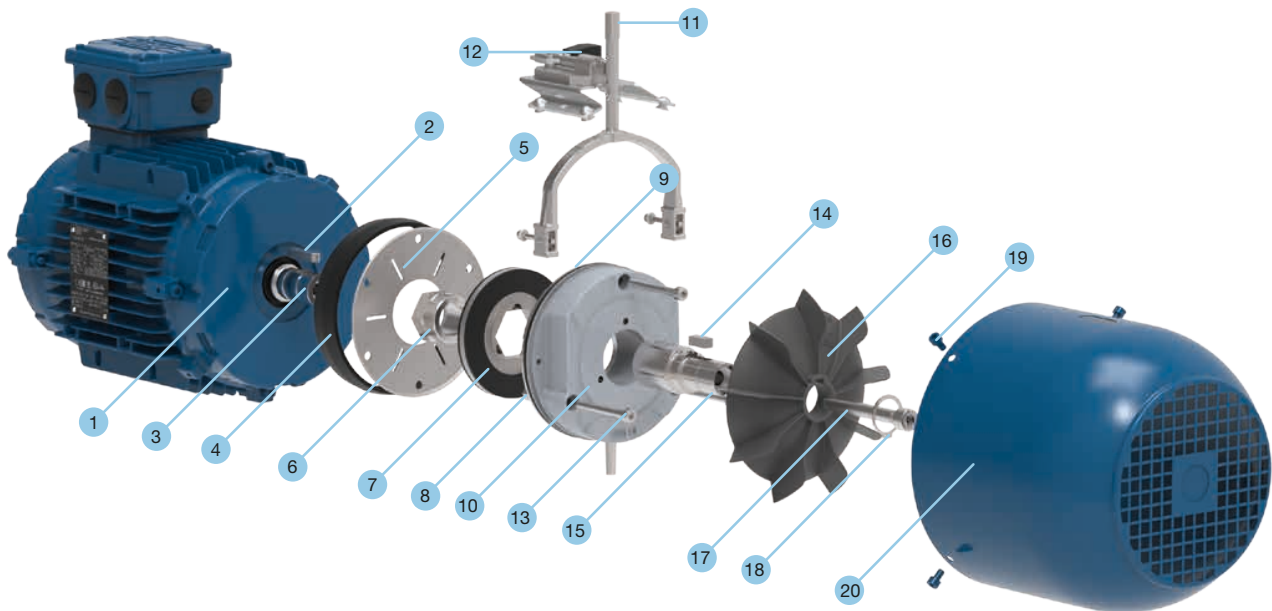

- |                                    |                                    |
|------------------------------------|------------------------------------|
| 1 Brake endshield                  | 11 Manual release lever (optional) |
| 2 Key                              | 12 Locking device                  |
| 3 Motor shaft                      | 13 Socket cap screw                |
| 4 Dust protection ring             | 14 Key                             |
| 5 Friction plate                   | 15 Brake shaft extension           |
| 6 Gear hub                         | 16 Fan                             |
| 7 Brake disc with friction linings | 17 Socket cap screw                |
| 8 Sleeve screws                    | 18 Retaining ring                  |
| 9 Armature disc                    | 19 Fan cover screws                |
| 10 Magnetic case                   | 20 Fan cover (brake execution)     |

Exploded view: Brake with manual release and locking device, frame size 100

### Brake selection

As shown in the following selection table, it is possible to supply brake motors with different brake torques to correspond to the most possible applications. It is also possible to achieve an optimal adaption, by means of the mode of connection of the brake. If exact values about the application are available, we recommend to calculate the braking torque according to the following formulas on page 396, otherwise the proportion between motor rated torque ( $M_N$ ) and braking torque ( $M_B$ ) can be taken as an indication for the dimensioning of the brake and check, if the safety factor is sufficient.

For normal applications we recommend sizing the brake 1.5 - 2 times the motor rated torque ( $M_N$ ), for special applications (lifting gears, switching operation, etc.) 2 - 3 times the motor torque and as holding brake approx. 1 time the rated torque.

- **Execution A - working brake**

$M_B$  approx. 1.5 - 2 times  $M_N$ , or applications with medium masses to be accelerated and medium number of starts

- **Execution B - holding brake**

$M_B$  approx. 1 time  $M_N$  for drives with small masses to be accelerated and number of starts resp. for keeping the drive stopped

### Brake selection table

IEC frame size	BR.. Standard brake		BBRHGD.. Double brake		BRGH.. Totally closed brake	
	Standard Execution A $M_B$	Execution B $M_B$	Standard Execution A $M_B$	Execution B $M_B$	Standard Execution A $M_B$	Execution B $M_B$
63	2 Nm	5 Nm	-	-	-	-
71	5 Nm	2 Nm	2 x 6 Nm	-	5 Nm	-
80	10 Nm	5 Nm	2 x 12,5 Nm	2 x 6 Nm	10 Nm	5 Nm
90	20 Nm	10 Nm	2 x 25 Nm	2 x 12,5 Nm	20 Nm	10 Nm
100	40 Nm	20 Nm	2 x 50 Nm	2 x 25 Nm	40 Nm	20 Nm
112	60 Nm	40 Nm	2 x 75 Nm	2 x 50 Nm	60 Nm	40 Nm
132	100 Nm	60 Nm	2 x 125 Nm	2 x 75 Nm	100 Nm	60 Nm
160	150 Nm	100 Nm	2 x 187 Nm	2 x 125 Nm	150 Nm	100 Nm
180	250 Nm	150 Nm	2 x 300 Nm	2 x 187 Nm	250 Nm	150 Nm
200	400 Nm	250 Nm	2 x 500 Nm	2 x 300 Nm	400 Nm	250 Nm
225	400 Nm	250 Nm	2 x 500 Nm	2 x 300 Nm	400 Nm	250 Nm
250	1000 Nm	-	2 x 1200 Nm	-	1000 Nm	-



Brake torque reduction						
Standard brake (BR..) and Totally closed brake "heavy duty" (BRGH..)				Double brake (BBRHGD..)		
Standard 7 springs	5 springs	4 springs	3 springs	Standard 7 springs	5 springs	4 springs
5 Nm	3,5 Nm	3 Nm	2 Nm	2 x 6 Nm	2 x 4 Nm	2 x 3.5 Nm
10 Nm	7 Nm	6 Nm	4 Nm	2 x 12.5 Nm	2 x 8.5 Nm	2 x 7 Nm
20 Nm	14 Nm	12 Nm	8 Nm	2 x 25 Nm	2 x 17.5 Nm	2 x 14 Nm
40 Nm	28 Nm	23 Nm	17 Nm	2 x 50 Nm	2 x 35 Nm	2 x 28 Nm
60 Nm	43 Nm	34 Nm	26 Nm	2 x 75 Nm	2 x 52 Nm	2 x 42 Nm
100 Nm	70 Nm	57 Nm	42 Nm	2 x 125 Nm	2 x 89 Nm	2 x 70 Nm
150 Nm	105 Nm	85 Nm	65 Nm	2 x 187 Nm	2 x 132 Nm	2 x 107 Nm
Standard 8 springs	6 springs	4 springs		Standard 8 springs	6 springs	4 springs
250 Nm	187 Nm	125 Nm		2 x 300 Nm	2 x 225 Nm	2 x 150 Nm
400 Nm	300 Nm	200 Nm		2 x 500 Nm	2 x 375 Nm	2 x 250 Nm
1000 Nm	500 Nm	-		-	-	-

Spring loaded brake: electrical characteristics

U <sub>2nenn</sub> =	U <sub>2</sub> =	Brake size		2	5	10	20	40	60	100	150	250	400	1000
		M <sub>B</sub>	[Nm]	2	5	10	20	40	60	100	150	250	400	1000
195	162-236	Coil current	[A]	0.13	0.13	0.18	0.2	0.26	0.32	0.42	0.5	0.65	0.85	0.83
		Power	[W]	26	26	36	38	50	63	82	99	127	165	162
		Resistance	[Ω]	1475	1475	1070	990	754	600	464	385	300	230	235
24	19-28	Coil current	[A]	1.14	1.14	1.44	1.7	2.1	2.7	3.3	4	5.2	7.3	-
		Power	[W]	27	27	34	41	50	65	80	96	125	175	-
		Resistance	[Ω]	21	21	16.7	14	11.6	8.9	7.2	6	4.6	3.3	-
102 <sup>1)</sup>	85-133	Coil current	[A]	0.3	0.3	0.38	0.45	0.53	0.6	0.85	0.94	1.23	1.76	-
		Power	[W]	31	31	38	46	54	60	87	95	125	179	-
		Resistance	[Ω]	340	340	271	228	192	174	120	109	83	58	-

■ standard brake

<sup>1)</sup> special execution (on demand)

Spring loaded brake: mechanical characteristics

Brake size		2	5	10	20	40	60	100	150	250	400	1000
M <sub>B</sub>	[Nm]	2	5	10	20	40	60	100	150	250	400	1000
M <sub>BS</sub>	[Nm]	-	7.5	15	30	60	90	150	225	375	600	1500
P <sub>20</sub>	[W]	26	26	36	38	50	63	82	100	127	165	162
J <sub>B</sub>	[kgm <sup>2</sup> x10 <sup>-3</sup> ]	0.015	0.015	0.045	0.172	0.45	0.86	1.22	2.85	6.65	19.5	45
P <sub>R</sub>	[J/s]	80	80	100	130	160	200	250	300	350	400	450
W <sub>Rmax</sub>	[Jx10 <sup>3</sup> ]	3	3	6	12	25	35	50	75	105	150	200
W <sub>RN</sub>	[Jx10 <sup>2</sup> ]	5	5	12	20	35	60	125	200	340	420	450
a <sub>normal</sub>	[mm]	0.2	0.2	0.2	0.3	0.3	0.3	0.4	0.4	0.5	0.5	0.6
a <sub>max</sub>	[mm]	0.6	0.6	0.7	0.8	0.9	1	1.1	1.1	1.2	1.2	1.7
b <sub>min</sub>	[mm]	4.5	4.5	5.5	7.5	9.5	11.5	12.5	14.5	16.5	16.5	21
m	[kg]	1.1	1.1	1.9	3.1	4.6	6.3	10	14.7	21.5	35	73
t <sub>2</sub> =	[ms]	35	35	45	60	80	120	160	200	220	300	320
t <sub>1</sub> ≈	[ms]	70	70	95	140	175	210	280	350	500	800	3000
t <sub>1</sub> =	[ms]	30	30	45	60	75	90	120	150	180	200	160
Fits on IEC motor frame size		63, 71	63, 71, 80	80, 90	90, 100	100, 112	112, 132	132, 160	160, 180	180, 200, 225	200, 225	250

	Designation	Unit
Rated torque of spring loaded brake	M <sub>B</sub>	[Nm]
Holding torque of the spring loaded brake	M <sub>BS</sub>	[Nm]
Brake coil power consumption	P <sub>20</sub>	[W]
Brake moment of inertia	J <sub>B</sub>	[kgm <sup>2</sup> ]
Friction performance	P <sub>R</sub>	[J/s]
Friction per switch cycle	W <sub>Rmax</sub>	[J]
Friction until readjustment	W <sub>RN</sub>	[J]
Air gap	a	[mm]

	Designation	Unit
Minimum brake rotor thickness	b	[mm]
Mass of moved machine parts	m	[kg]
Engaging time	t <sub>1</sub>	[ms]
Release time of brake	t <sub>2</sub>	[ms]
Output voltage DC rectifier	U <sub>2</sub> =	[V]
For DC switching	=	-
For AC switching	≈	-

## BR.. - Spring loaded brake

Degree of protection IP55. The braking torque is adjustable with reduction of the springs (see page 391).

<p><b>BR..</b> Spring loaded brake without additional options</p> <p><b>Possible options:</b></p> <p><b>BRH..</b> With manual release</p> <p><b>BRHA..</b> With manual release and locking device</p> <p><b>BRR..</b> With corrosion protection IP55</p> <p><b>BRS..</b> With dust protection IP65</p> <p><b>BRSR..</b> With dust and corrosion protection IP65</p> <p><b>BRGD..</b> Low noise execution</p>	→	<p><b>Ordering examples:</b></p> <p><b>BR5</b> Brake 5 Nm</p> <p><b>BRHASRGD40</b> Brake 40 Nm with manual release, locking device, dust and corrosion protection and low noise execution</p>
--	---	---

### BRM - Micro switch

When brake release monitoring is necessary, a micro switch (5) can be fitted to indicate brake release. This signal can be used to start the electric motor. When air gap "a" (see page 389) is at its maximum and the armature is no longer attracted to the magnet body the motor will not start and air gap "a" must be adjusted. The installation of the micro switch is possible for brakes > 5 Nm.

### BRH.. - Manual release

The installation of the manual release is possible for brakes > 5 Nm. The manual release (1) is necessary for manually releasing the brake in cases of power failure. Brakes will be supplied with manual releases fitted by factory. The adjustment of the manual release may not be changed, not even when air gap "a" (see page 389) is readjusted, as safety can be adversely affected.

### BRHA.. - Manual release with locking device

In case of service the manual release can be fastened with a locking device. Take care that in rated condition the brake is released (see illustration on page 394). The 0° position of the manual release with locking device is **only possible** with motor frame sizes 100, 160, 180, 200, 225 and 250.

### BRR.. - Corrosion protection

Protection class IP55. Consists of painted brake endshield and friction plate (3), which is made of non-corrosive material.

### BRS.. - Dust protection

Protection class IP65. Consists of friction plate (3), which is made of non-corrosive material, dust protection ring (2) and shaft seal.

### BRSR.. - Corrosion and dust protection

Protection class IP65. Consists of painted brake endshield, friction plate (3), which is made of a non-corrosive material, dust protection ring (2) and shaft seal.

### BRGD.. - Low noise execution

To reduce the switching noises of the spring loaded brake, the o-ring (4) can be inserted between armature plate and brake body.

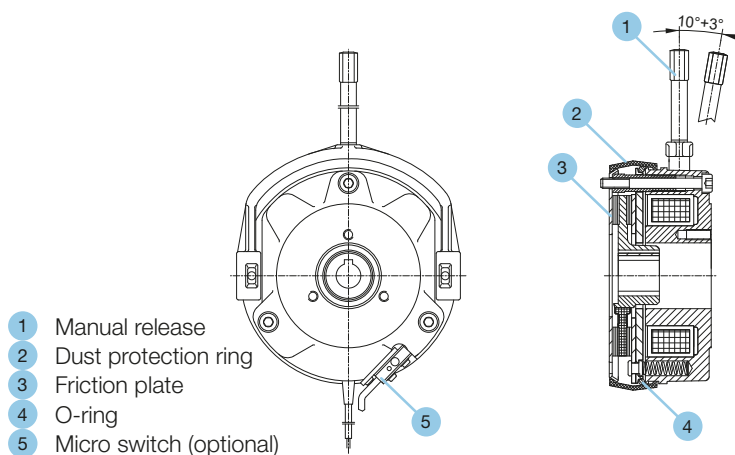

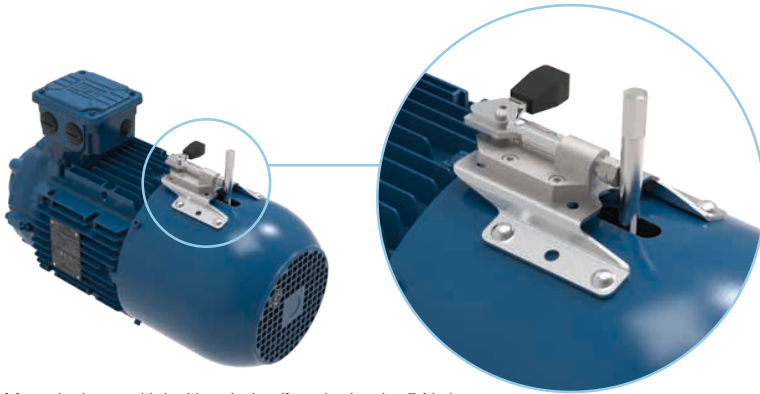

Manual release with locking device (from brake size 5 Nm)

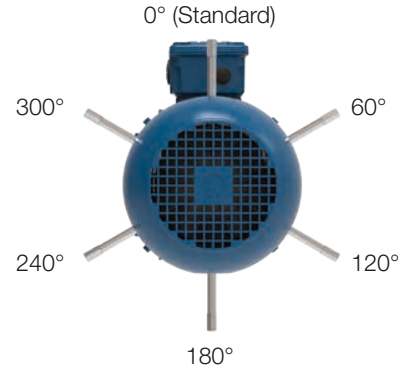

Possible positions of the manual release at the view of the motor fan cover. (The 0° position of the manual release with locking device is only possible with motor frame sizes 100 and from 160.)

### BBRHGD.. - Double spring loaded brake

Double brakes (from motor frame size 71) are two specially designed low noise brakes working independently of each other meeting high demands on safety.

As option a micro switch (5) is monitoring the function of the brakes. The brakes are executed per default in low noise execution and with manual release. Braking torque is adjustable with reduction of the springs (see page 391).

M

<p><b>BBRHGD..</b> Double brake in low noise execution with manual release (standard)</p> <p><b>Possible options:</b></p> <p><b>BBRHSGD..</b> With dust protection IP65</p> <p><b>BBRGD..</b> Without manual release</p>	➔	<p><b>Ordering examples:</b></p> <p><b>BBRHGD6</b> Double brake 2 x 6 Nm in low noise execution with manual release</p> <p><b>BBRHSGD187</b> Double brake 2 x 187 Nm in low noise exec. with man. release and dust protection</p>
--	---	---

### BBRM - Micro switch

When brake release monitoring is necessary, a micro switch (5) can be fitted to indicate brake release. This signal can be used to start the electric motor. When air gap "a" (see page 389) is at its maximum and the armature is no longer attracted to the magnet body the motor will not start and air gap "a" must be re-adjusted.

### BBRHSGD.. - Dust protection

Protection class IP65. Consists of friction plate (3), which is made of non-corrosive material, dust protection ring (2) and shaft seal.

### BBRHGD.. - Manual release

The manual release (1) for manually releasing of the brake in cases of power failure. Brakes will be supplied in standard with manual release fitted by factory. The adjustment of the manual release may not be changed, not even when air gap "a" (see page 389) is readjusted, as security can be adversely affected.

Possible positions of the manual release see on page 394.

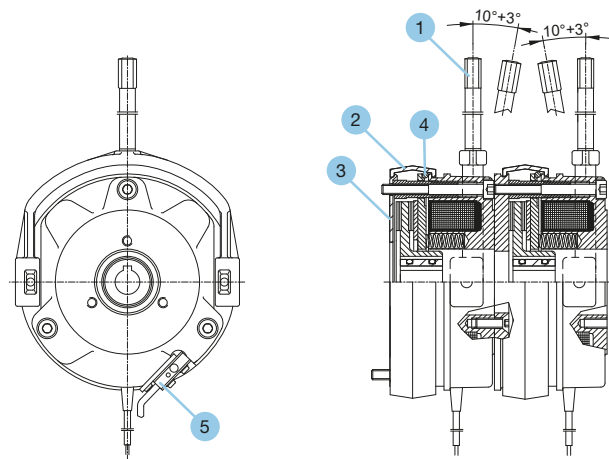

- 1 Manual release
- 2 Dust protection ring
- 3 Friction plate
- 4 O-ring
- 5 Micro switch (optional)

### BRGH - Totally closed spring loaded brake „heavy duty“

The fully capsulated brake design with dust and waterproof cable glands is in accordance with protection degree IP66. On ventilated motor executions IC411 the shaft passage is sealed by sealrings. The brake is executed with manual release in standard. On the brake disc a lining for high loads is fitted. Brake selection table see page 391.

<p><b>BRGH..</b> Totally closed spring loaded brake with manual release</p> <p><b>Possible options:</b></p> <p><b>BRGHA..</b> With manual release and locking device</p> <p><b>BRG..</b> Without manual release</p>		<p><b>Ordering examples:</b></p> <p><b>BRGH10</b> Brake 10 Nm with manual release</p> <p><b>BRGHA150</b> Brake 150 Nm with manual release and locking device</p>
---	--	--

#### BRGH.. - Manual release

The manual release (1) is necessary for manually releasing the brake in cases of power failure. Brakes will be supplied in standard with manual release fitted by factory.

The adjustment of the manual release may not be changed, not even when air gap “a” (see page 389) is readjusted, as safety can be adversely affected.

Possible positions of the manual release see on page 394.

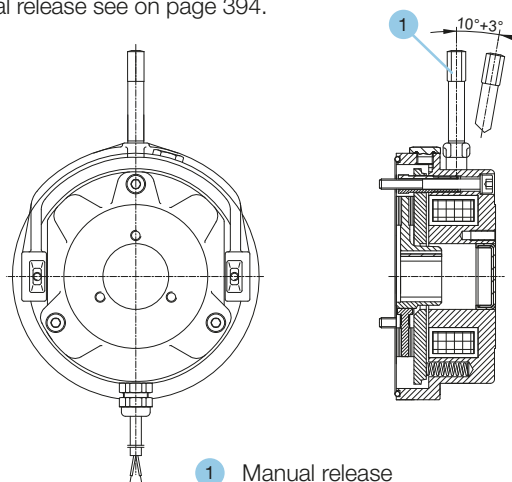

#### Anti-condensation heating for brakes

When operating at conditions of extreme temperature changes or extreme climatic conditions, the windings are endangered of condensation water. The built in anti-condensation heater warms up the magnet windings after switching off and prevents the brakes inside from condensation water.

The anti-condensation heating must be supplied with a separate voltage.

Supply voltage 230 V (1~)

Voltage range: 220 - 230 V, 50/60 Hz

Brake size [Nm]	Performance [W]
10	16
20	29
40	33
60	35
100	48
150	53
250	70
400	128
1000	131

### Calculation of the brake torque

If the mass moment of inertia, the rotation speed and the permissible braking time of the machine are known, the torque of the spring loaded brake can be calculated.

	Formula	Unit
Load moment (static load)	$M_L = F \cdot r$	[Nm]
Braking torque (dynamic load) There is a pure dynamic load if fly-wheels, rolls, etc. have to be slowed down and when the static load is very insignificant.	$M_a = 1,046 \cdot 10^2 \cdot J_{zus} \cdot \frac{n}{t - t_1}$ $M_{aerf} = M_a \cdot K \leq M_B$	[Nm]
Braking torque (dynamic and static load) In most applications there is also dynamic load in addition to static load.	$M_{aerf} = (M_a \pm M_L) \cdot K$ $M_{aerf} = (1,046 \cdot 10^2 \cdot J_{zus} \cdot \frac{n}{t - t_1} \pm M_L) \cdot K$ $M_{aerf} \leq M_B$	[Nm]
Estimated determination of braking torque	$M_{aerf} = 9,55 \cdot 10^3 \cdot \frac{P}{n} \cdot K$ $M_{aerf} \leq M_B$	[Nm]
Deceleration time	$t = t_B + t_1$	[ms]
Acceleration time	$t_A = \frac{J_{ges} \cdot n_1}{9,55 \cdot (M_A \pm M_L)} + t_2$ $J_{ges} = J_E + J_{zus}$	[s] [kgm <sup>2</sup> ]
Braking time	$t_B = \frac{J_{ges} \cdot n_1}{9,55 \cdot (M_A \pm M_L)}$ $J_{ges} = J_E + J_{zus}$	[s] [kgm <sup>2</sup> ]
The conversion of several mass moments of inertia with different rotation speeds in a mass moment of inertia reduced to the motor shaft	$J_{zus} = \frac{J_2 \cdot n_2^2 + J_3 \cdot n_3^2 \dots}{n_1^2}$	[kgm <sup>2</sup> ]
Conversion of straight-line moved machine parts into a corresponding J on the motor shaft	$J = 91,2 \cdot m \cdot \frac{v^2}{n_1^2}$	[kgm <sup>2</sup> ]
Friction per switch cycle	$W_R = \frac{J_{zus} \cdot n^2}{182,5} \cdot \frac{M_B}{M_B \pm M_L}$ $W_R < W_{Rmax}$	[J]
Friction performance	$P_R = W_R \cdot S$ $P_R < P_{Rmax}$	[J/s]

M

Designation	Unit	Description
$M_L$	[Nm]	Load moment Sign + : when the load moment acts decelerating (lifts when going up) Sign - : when the load moment acts accelerating (lifts when going down)
$M_{aerf}$	[Nm]	Necessary braking torque
$M_a$	[Nm]	Braking torque
$M_A$	[Nm]	Starting torque of motor
$M_B$	[Nm]	Rated torque of spring loaded brake
K	-	Safety factor according to the operating conditions (1...3)
F	[N]	Force
$F_I$	-	Factor of inertia
r	[m]	Lever arm
m	[kg]	Mass of moved machine parts
J, J <sub>1</sub> , J <sub>2</sub>	[kgm <sup>2</sup> ]	Mass moment of inertia
J <sub>E</sub>	[kgm <sup>2</sup> ]	Proper mass moment of inertia
J <sub>ges</sub>	[kgm <sup>2</sup> ]	Total mass moment of inertia
J <sub>mot</sub>	[kgm <sup>2</sup> ]	Mass moment of inertia of the motor

Designation	Unit	Description
J <sub>zus</sub>	[kgm <sup>2</sup> ]	Additional mass moment of inertia
K	-	Safety factor $K \geq 2$
P	[kW]	Power
$P_R$	[J/s]	Friction performance
$P_{Rmax}$	[J/s]	Maximum friction performance
n	[min <sup>-1</sup> ]	Rotation speed
n <sub>1</sub>	[min <sup>-1</sup> ]	Rotation speed of motor
n <sub>2</sub> , n <sub>3</sub>	[min <sup>-1</sup> ]	Rotation speeds
t	[ms]	Deceleration time
t <sub>A</sub>	[s]	Acceleration time
t <sub>B</sub>	[s]	Braking time
t <sub>1</sub>	[ms]	Engaging time
t <sub>2</sub>	[ms]	Release time of brake
v	[m/s]	Speed
W <sub>R</sub>	[J]	Friction work per switch cycle
W <sub>Rmax</sub>	[J]	Permissible friction per switch cycle
S	[s <sup>-1</sup> ]	Number of switch cycle per second



## Rectifier

### Power supply

The DC-brake coil is normally supplied by a half wave rectifier incorporated in the motor terminal box and is also available for coil voltages 162-236 V DC, 85-133 V DC or 24 V DC (24 V with block terminal for external power supply!) Corresponding rectifiers and coil voltages are optionally available for all special voltages. The rectifiers are equipped with varistors to protect them against over-voltages.

At number of starts more than 1/s, please contact us for rectifier loading capacity.

### Switching modes

By default brake motors will be delivered with connected rectifier for AC-side switching. For DC-side switching the bridge between terminals 5 and 6 must be removed and a switching contact must be connected. Start-up of motor only with connecting brake.

- **AC-side switching** is executed before the rectifier on AC-side. Here the magnetic field is de-energised slowly, the brake interrupts softly with delay. (Release time  $t_{1\approx}$ )
- **DC-side switching** is executed between rectifier and coil. Thereby an extremely low degree of overrunning is achieved. For all gear units, which require exact braking, especially for lifting gears, a DC-side switching of the brake is absolutely required. (Release time  $t_1\approx$ )

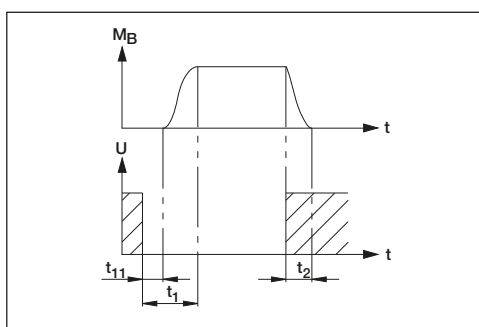

	Designation	Unit
Braking torque	$M_B$	[Nm]
Voltage	$U$	[V DC]
Engaging time	$t_1$	[ms]
Response delay (time from switching power off until braking torque increases)	$t_{11}$	[ms]
Release time (time from switching power on until braking torque begins to decrease)	$t_2$	[ms]

### Rectifier selection

- *Half-wave and bridge rectifier*

The half wave rectifier which halves the supply voltage is the most cost effective. The bridge rectifier produces 90 % DC voltage from the AC supply voltage. Both rectifiers are available for switching on AC or DC side. Varistors in the input and output protect the rectifiers against surge voltages.

Half-wave rectifier:  $U_{2=} = 0.45 \times U_{1\sim}$   $I_{\max} = 1 \text{ A}$

Bridge rectifier:  $U_{2=} = 0.9 \times U_{1\sim}$   $I_{\max} = 2 \text{ A}$

- *Fast excitation rectifier*

For motor frame sizes 63-132 this rectifier can't be installed in the standard terminal box.

The high-speed rectifier uses special connections to make different direct voltages available on the terminals. This means that the following brake operating modes can be selected:

1. Rapid response: Brake voltage level equal to the holding voltage of the fast excitation rectifier: The ventilation time of the brake is reduced.
2. Power reduction: Brake voltage level equal to overexcitation voltage of the fast excitation rectifier: reduced performance losses in the brake coil, engage time of the brake is reduced.

Max. connection voltage:  $U_{1\sim} = 500 \text{ V AC}$

Max. permissible connections: 600 connections/h

Max. permissible switching capacity: 210 W

Rectifier type	System	$U_N$ [V]	$I_N$ [A]
FBGR-E500/220-GS	Half-wave rectifier	500	1
FBGR-B400/345-GS	Bridge rectifier	400	2
FBGR-S500/220-GS480	Fast excitation rectifier	500	2

Overexcitation phase (voltage)	$T = 0 - 500 \text{ ms } (\pm 200 \text{ ms})$	$U_{2=} = 0.9 \times U_{1\sim}$	$I_N = 4 \text{ A}$
Holding phase (voltage)	$T > 500 \text{ ms}$	$U_{2=} = 0.45 \times U_{1\sim}$	$I_N = 2 \text{ A}$

### Connection examples

3~ U <sub>N</sub> [V]	Connection	U <sub>1~</sub> [V]	Rectifier type	Designation U <sub>1~</sub>	U <sub>2=</sub> [V]	Brake coil voltage [V]
380-420-480		380-420-480	FBGR-E500/220-GS	480 V~	169-187-214	195 (162-236)
380-420-480		380-400-480	FBGR-E500/220-GS	480 V~	169-187-214	195 (162-236)
660-690-725		380-400-420	FBGR-E500/220-GS	480 V~	169-187-214	195 (162-236)
220-240		220-240	FBGR-B400/345-GS	230 V~	195-214	195 (162-236)
330-365-415		190-210-240	FBGR-B400/345-GS	230 V~	169-187-214	195 (162-236)
190-210-240		190-210-240	FBGR-B400/345-GS	230 V~	169-187-214	195 (162-236)
500		500	FBGR-E500/220-GS	480 V~	223	195 (162-236)
380-420-480		220-240-280	FBGR-E500/220-GS	480 V~	98-107-125	102 (85-133) <sup>1)</sup>
220-240-280		220-240-280	FBGR-E500/220-GS	480 V~	98-107-125	102 (85-133) <sup>1)</sup>
330-365-415		190-210-240	FBGR-E500/220-GS	480 V~	85-94-107	102 (85-133) <sup>1)</sup>
190-210-240		190-210-240	FBGR-E500/220-GS	480 V~	85-94-107	102 (85-133) <sup>1)</sup>
500		290	FBGR-E500/220-GS	480 V~	129	102 (85-133) <sup>1)</sup>

standard brake

<sup>1)</sup> special execution

	Designation	Unit
Maximum rated output current DC rectifier	I <sub>N</sub>	[A]
3~ rated motor voltage	3~ U <sub>N</sub>	[V]
Maximum rated input voltage AC rectifier	U <sub>N</sub>	[V]
Supply voltage AC rectifier	U <sub>1~</sub>	[V]
Output voltage DC rectifier	U <sub>2=</sub>	[V]

### Switching diagram for braking motor (star-delta connection)

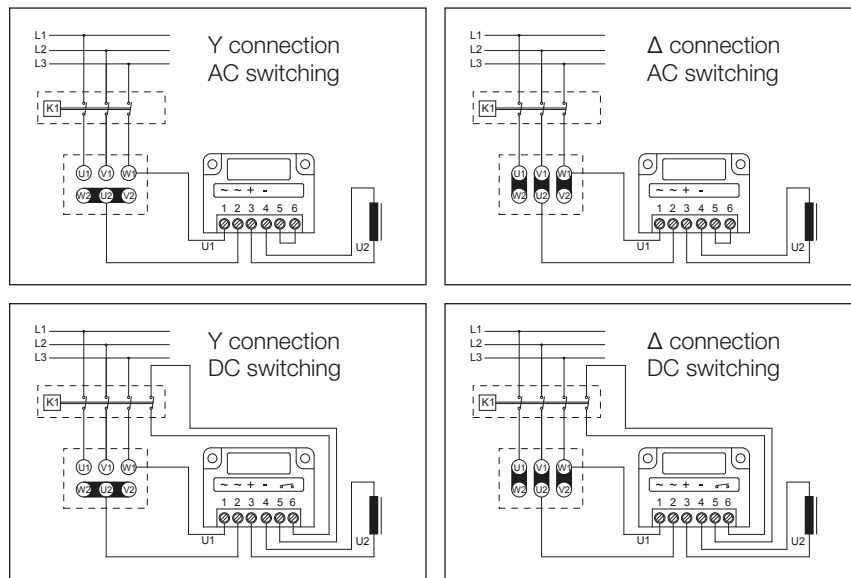

### Back stop

Installing a back stop guarantees that the motor

- can start only in one direction
- can't be turned in wrong direction from counteract torques

**KKM** Back stop (IEC frame size 63 to 90)

**RSM** Back stop (IEC frame size 100 to 250)

The applied free wheels of the clamping bodies are mounted on the motor endshield (NDE) in such a manner, that the standard motor dimension LB up to motor size 90 will not be lengthened. From motor size 100 the motor dimension LB1 is valid. The back stop has been largely dimensioned and corresponds approx. to the motor starting torque (M<sub>A</sub>) to prevent a damage in case of short-time-starting against the back stop at switchings made by error. Nevertheless, the free direction of rotation must be determined first, especially at big motor powers and we recommend for the first starting the star connection and only then the delta connection at correct rotation.

### Fields of application:

- Drives for elevators and inclined lifts
- Pumps and fans with backpressure ratchet
- Gearmotors for conveyors with non-reverse characteristic

#### KKM - Back stop (ball bearing free-wheelings)

The elements have bearing characteristics and are used instead of the bearing on the fan side. The outer dimensions are identical to the deep-groove ball bearings.

##### ▪ Function

Rolling elements and spring loaded clamping bodies are built in between inner and outer ring. The rolling elements and ratchet elements are fixed in a plastic cage. Torque transmitting is made by tight fits on the inner and outer ring. The elements are grease prelubricated. They are maintenance-free for 10,000 to 20,000 hours under normal working conditions.

##### ▪ Mounting

The KKM back stop will be mounted instead of the bearing on the non-driven side.

#### RSM - Back stop (with centrifugal mechanism)

Because the mounted back stops have no bearing properties, they are mounted directly near the non-drive bearing. Above the lifting speed the centrifugal elements are working contactless and so they are maintenance free under normal conditions.

##### ▪ Mounting

The centrifugal elements are mounted directly near the non-driven side bearing between bearing and fan under the fan cover. The inner ring of the back stop is connected with the shaft with a key DIN 6885-1.

##### ▪ Direction of rotation

The direction of rotation has to be given with the ordering.

##### ▪ Back stop direction

Back stop direction at a view on output shaft right or left.

By turning the entire back stop system by 180°, the back stop direction can be reversed (applies only for RSM!).



### Back stop overview

IEC frame size	Back stop type	Torque [Nm]	Motor length dimension (see page 380)
63	KKM	7.4	LB
71	KKM	13.5	LB
80	KKM	40	LB
90	KKM	68	LB
100	RSM	150	LB1
112	RSM	150	LB1
132	RSM	390	LB1
160	RSM	580	LB1
180	RSM	580	LB1
200	RSM	1050	LB1
225	RSM	1050	LB1
250	RSM	2100	LB1

## Encoder systems

- I. Encoder outside the fan cover
- S. Encoder inside the fan cover



Encoder outside the fan cover



Standard position connector (M23)

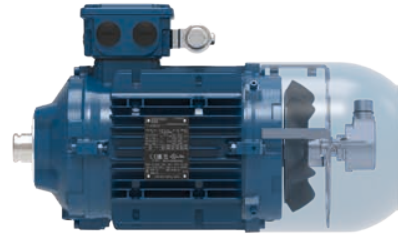

Encoder inside the fan cover

### Modular design

We are using encoders with hollow shaft ( $\varnothing$  12 mm) open at one end. The modular motor shafts are fit to attach an encoder set. The mounting of encoders therefore is easy and immediately possible. Add-on kits are easy to retrofit.

### Mounting of encoders

The encoders are equipped with an integral bearing and connected directly on the non-driven motor shaft side. During angular acceleration of the shaft the stator coupling must absorb only the torque resulting from friction in the bearing.

### IG, SG - Standard encoder

Available for IEC motor frame sizes 63 to 250 (IG) / 71 to 250 (SG)

Type: Kübler Sendix 5020

Pulses per revolution: 1024

Output signal: HTL or TTL

Voltage supply: 10-30 V at HTL, 5 V at TTL

Degree of protection: IP66

IG standard: with PIN connector (M23) on the encoder

SG standard: with PIN connector (M23) on the terminal box (mating connector not included in delivery)

Other numbers of pulses per revolution on request.

### IC, SC - SINCOS encoder

Available for IEC motor frame sizes 80 to 225 (IC) / 80 to 250 (SC)

Pulses per revolution: 1024

Output signal: Sinus 1VSS

Voltage supply: 10-30 V or 5 V

IC standard: with PIN connector (M23) on the encoder

SC standard: with PIN connector (M23) on the terminal box (mating connector not included in delivery)

Other numbers of pulses per revolution on request.

Encoders in standard mechanical designs can also be implemented as electric SINCOS versions. In this case, signals A and B are available on the output as sinusoidal voltage signals with a signal level of 1 VSS or one 0 pulse once per rotation. These can be used in many different ways in the downstream electronics. Via interpolation of the two signals shifted by  $90^\circ$ , very high resolutions are achieved and can therefore also be used with very slow movements for speed control.

### IR, SR - Resolver

Available for IEC motor frame sizes 71 to 200

Degree of protection: IP54 (IP66 on request)

IR standard: with 0.6 m cable (open one way, 6 strands)

SR standard: with 0.6 m cable (open one way, 6 strands)

Resolvers are primarily 2-pole, electromagnetic measuring transducers for converting the angle position of a rotor into an electrical value. Resolvers are wear-free and robust, as the most important elements for acquiring the information consist only of iron core and copper coils. Contamination therefore plays a lesser role.

The configuration consists of 2 stator coils positioned at an offset of  $90^\circ$  (S1/S3 and S2/S4) and a rotating rotor coil (R1/R2).

In this process, the rotor coil supply is inductive, in other words, brushless. The R1/R2 rotor coil is excited using a sinusoidal alternating voltage. The amplitudes of the voltages induced in stator coils S1/S3 and S2/S4 depend on the rotor angle.

Input voltage:  $E_{(R1/R2)} = E \times \sin(\omega t)$

Output:  $E_{(S1/S3)} = T_r \times E_{(R1/R2)} \times \cos(\varphi)$   
 $E_{(S2/S4)} = T_r \times E_{(R1/R2)} \times \sin(\varphi)$

Standard input voltage:  $E_{(R1/R2)} = 7 \text{ V}$   
 Standard transformation ratio:  $T_r = 0.5$

### SS - SSI multi turn encoder

Available for IEC motor frame sizes 71 to 250  
 Digits per revolution: 8192 at 4096 possible rotations  
 Output signal: TTL  
 Voltage supply: 5 V  
 Degree of protection: IP66  
 SS standard execution: with PIN connector on the terminal box

The SSI multiturn absolute encoder signals a single exactly defined position to the drive frequency controller. Maximum permissible number of motor revolutions can be 4096. The resolution is 8192 steps per revolution. The serial communication is corresponding to the specification of the SSI-protocol. SSI means Synchronous Serial Interface.

The permissible cable length is 100 m at least if EMC-compatible wiring is guaranteed.

### SV - Heavy Duty encoder

Available for IEC motor frame sizes 90 to 250  
 Pulses per revolution: 1024  
 Output signal: HTL or TTL  
 Voltage supply: 10 - 30 V at HTL, 5 V at TTL  
 Degree of protection: IP65  
 Optional insulation inserts available to protect against shaft currents.

The Heavy Duty encoder boasts a high degree of ruggedness in a very compact design. Its special construction makes it perfect for all applications in very harsh environments.

### IA, SA - Special encoder

The mounting of special encoders is possible on request.

#### Type of signal

##### HTL-/TTL - output signal

Encoders with HTL/TTL square-wave output signals incorporate a circuit that digitises scanning signals, providing two 90° (el.) phase-shifted HTL-/TTL square-wave pulse trains  $U_{a1}$  and  $U_{a2}$  and a reference pulse  $U_{a0}$ , which is gated with the incremental signals  $U_{a1}$  and  $U_{a2}$ .

The integrated electronics also generate the inverse signals of all square-wave pulse trains. The distance between two successive edges of the combined pulse trains  $U_{a1}$  and  $U_{a2}$  is one measuring step. HTL/TTL square-wave signals can be transmitted to the subsequent electronics (without inverting: max. cable length 100 m; with inverting: 250 m), provided that the specified  $5 \text{ V} \pm 5 \%$  supply voltage is maintained at the encoder.

Extended cable length is possible with fiber-optic cable.

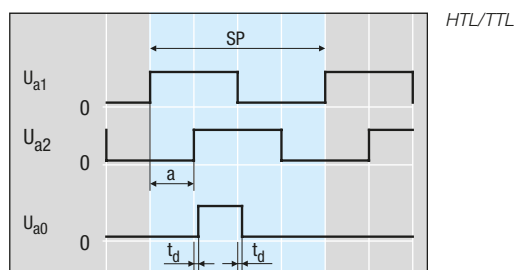

##### HTL signal levels

$U_H \geq 2.1 \text{ V}$  at  $I_H = 20 \text{ mA}$   
 $U_L \leq 2.8 \text{ V}$  at  $I_L = 20 \text{ mA}$   
 with power supply +24 V, without cable

##### TTL signal levels

$U_H \geq 2.5 \text{ V}$  at  $I_H = 20 \text{ mA}$   
 $U_L \leq 0.5 \text{ V}$  at  $I_L = 20 \text{ mA}$

▪ **1VPP - output signals**

The sinusoidal incremental signals  $U_{a1}$  and  $U_{a2}$  are phase-shifted by  $90^\circ$  and have signal levels of approximately 1VPP. The signal peaks from the reference mark signal have a usable component of approximately 0.5 V.

Signal interpolation and digitalisation can be performed by electronics, which output TTL-compatible signals.

Voltage signals can be transmitted to the subsequent electronics unit over cables as long as 50 m, provided that the specified  $5\text{ V} \pm 5\%$  supply voltage is maintained at the encoder. Encoders that produce voltage signals have sensor line connections for detection of the supply voltage at the encoder; corresponding control systems in the subsequent electronics can then maintain the voltage tolerance.

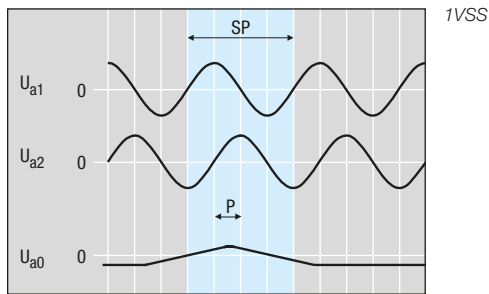

	Designation
Encoder signals	$U_{a1}, U_{a2}$
Reference pulse	$U_{a0}$
Signal level HIGH	$U_H$
Signal level LOW	$U_L$
Edge separation	a
Phase shift	P
Current at signal level HIGH	$I_H$
Current at signal level LOW	$I_L$
Signal period	SP
Delay time	$t_d$



## Ventilation systems

<b>FL</b>	Forced ventilation
<b>ZL</b>	Fly wheel fan
<b>ZM</b>	Metal fan
<b>U</b>	Non-ventilated without NDE shaft end
<b>UW</b>	Non-ventilated with NDE shaft end

### FL - Forced ventilation (TEFV, IC416)

IEC frame sizes: 63 to 250

At applications with high starting frequencies, startings against heavy masses, heavy alternating load and operations with frequency inverters, self ventilation of the motor sometimes will not be sufficient and forced ventilation is necessary.

At frequencies under 30 Hz forced ventilation is recommended in order not to thermally overstrain the motor.

### Forced ventilation currents (2 pole ventilation motor)

IEC frame size	Phases Connection	Capacitor μF	50 Hz					60 Hz				
			Voltage range V	Current A <sup>1)</sup>	Power W <sup>1)</sup>	Air current capacity m³/h	Noise level db(A)	Voltage range V	Current A <sup>1)</sup>	Power W <sup>1)</sup>	Air current capacity m³/h	Noise level dB(A)
63	3~Y	-	346-525	0.09	28	54	47	380-575	0.08	29	69	52
	3~Δ	-	200-303	0.15	28			220-332	0.14	29		
	1~Δ	1.5	230-277	0.18	46			230-277	0.21	54		
71	3~Y	-	346-525	0.09	29	78	51	380-575	0.07	28	99	56
	3~Δ	-	200-303	0.15	29			220-332	0.13	28		
	1~Δ	1.5	230-277	0.18	48			230-277	0.21	56		
80	3~Y	-	346-525	0.09	33	128	54	380-575	0.07	36	151	58
	3~Δ	-	200-303	0.16	33			220-332	0.13	36		
	1~Δ	1.5	230-277	0.19	48			230-277	0.22	59		
90	3~Y	-	346-525	0.22	78	216	59	380-575	0.18	71	258	63
	3~Δ	-	200-303	0.39	78			220-332	0.32	71		
	1~Δ	3.0	220-277	0.29	59			220-277	0.23	61		
100	3~Y	-	346-525	0.21	80	278	60	380-575	0.18	80	328	65
	3~Δ	-	200-303	0.37	80			220-332	0.30	80		
	1~Δ	3.0	220-277	0.29	62			220-277	0.28	73		
112	3~Y	-	346-525	0.20	87	355	62	380-575	0.17	93	418	66
	3~Δ	-	200-303	0.35	87			220-332	0.29	93		
	1~Δ	3.0	220-277	0.27	64			220-277	0.36	88		
132	3~Y	-	346-525	0.37	160	550	67	380-575	0.32	180	650	71
	3~Δ	-	200-303	0.64	160			220-332	0.55	180		
	1~Δ	6.0	230-277	0.52	125			230-277	0.61	163		
160	3~Y	-	346-525	0.74	314	980	73	380-575	0.62	391	1160	77
	3~Δ	-	200-303	1.28	314			220-332	1.08	391		
	1~Δ	12	230-277	1.05	246			230-277	1.52	390		
180	3~Y	-	346-525	0.74	314	1200	74	380-575	0.62	391	1379	80
	3~Δ	-	200-303	1.28	314			220-332	1.08	391		
	1~Δ	12	230-277	1.05	246			230-277	1.52	390		
200	3~Y	-	346-525	0.74	314	1324	74	380-575	0.62	391	1575	81
	3~Δ	-	200-303	1.28	314			220-332	1.08	391		
	1~Δ	12	230-277	1.05	246			230-277	1.52	390		
225	3~Y	-	346-525	0.74	314	1324	74	380-575	0.62	391	1575	81
	3~Δ	-	200-303	1.28	314			220-332	1.08	391		
	1~Δ	12	230-277	1.05	246			230-277	1.52	390		
250	3~Y	-	346-525	0.74	314	1324	74	380-575	0.62	391	1575	81
	3~Δ	-	200-303	1.28	314			220-332	1.08	391		
	1~Δ	12	230-277	1.05	246			230-277	1.52	390		

1) maximum permissible values

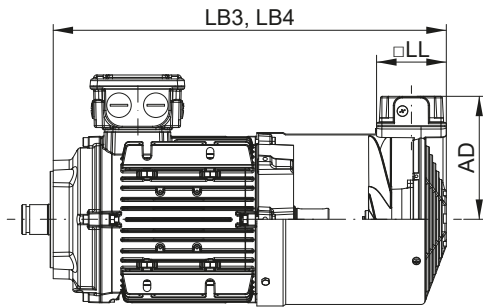

IEC frame size	AD	□LL
63	118	107
71	124	107
80	134	107
90	143	107
100	152	107
112	164	107
132	185	107
160	211	107
180	211	107
200	211	107
225	211	107
250	211	107

Dimensions in mm. Dimensions LB3 and LB4 see drawings from page 380

### ZL - Fly wheel fan

IEC frame sizes: 71 to 132 (special execution)

Fly wheel fans increase the inertial moment of the standard motors by a multiple and help to decrease the start up time of the motors. Motors with fly wheel fan often are used at crane drives or machine-systems where a soft start up is required.

Available for motor sizes 71 to 132 on request, exchangeable without modification with standard fan, pay attention to the reduced starting frequency! Braking by reversal and driving up against a buffer stop is not permissible.

Motor without brake:  $J_{ges} = J_{mot} + J_{ZL}$

Brake motor:  $J_{ges} = J_{mot} + J_{ZL} + J_B$

	Designation	Unit
Total mass moment of inertia	$J_{ges}$	[kgm <sup>2</sup> ]
Mass moment of motor	$J_{mot}$	[kgm <sup>2</sup> ]
Mass moment of brake	$J_B$	[kgm <sup>2</sup> ]
Mass moment of fly wheel fan	$J_{ZL}$	[kgm <sup>2</sup> ]
Weight of fly wheel fan	m	[kg]

IEC frame size	$J_{ZL}$ [kgm <sup>2</sup> ] x 10 <sup>-3</sup>	m [kg]
71	2	1.3
80	2	1.3
90	3	1.6
100	10	3.3
112	10	3.3
132	14	3.8



### ZM - Metal fan

IEC frame size: 63 to 250

For ambient temperatures which are lesser than or greater than the operation temperatures of the standard plastic fan wheels, the ventilation can be provided via metal fan wheels. These can be manufactured from aluminium, steel plate or cast iron. Using a metal fan can be appropriate in the event of difficult climatic conditions.

### U - Non-ventilated without NDE shaft end (TENV)

IEC frame size: 63 to 250

In this version, there is no fan or fan cover. The NDE is completely enclosed. A cover plate is used as the sealing component. This prevents dirt, water, etc. from entering the motor.

### UW - Non-ventilated with NDE shaft end (TENV)

IEC frame size: 63 to 250

This design is realised by omitting the fan. The standard fan cover is used as contact protection for the remaining NDE rotating shaft. Motors of these designs are intended for use in systems where fans or fan covers integrated into the motor are not appropriate due to the environmental conditions, for design reasons or at the customer's request.

The motors are therefore designed without integrated fans or fan covers.

In the non-ventilated version, the resulting reduction in nominal motor output must be observed!





## Additional modules

<b>HR</b>	Hand wheel
<b>SD</b>	Protection cap
<b>ID</b>	Protection cap for encoders
<b>ZWM</b>	Second shaft end - module shaft
<b>ZWV</b>	Second shaft end - solid shaft

### HR - Hand wheel

IEC frame sizes: 71 to 250

By using a second shaft end it is possible to fit a hand wheel.

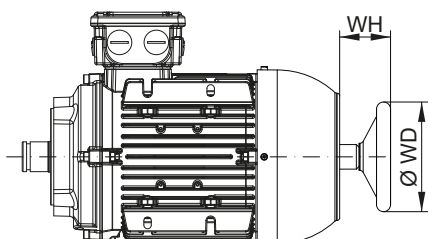

IEC frame size	ØWD	WH
71	125	51
80	125	51
90	125	51
100	125	51
112	125	51
132	200	60
160	200	60
180	200	60
200	200	60
225	200	60
250	200	60

Dimensions in mm.

### SD - Protection cap

IEC frame sizes: 63 to 250

When installed vertically with the shaft downward, e.g. IM V1, the air intake opening can be protected against water and foreign substance by means of a protective cap.

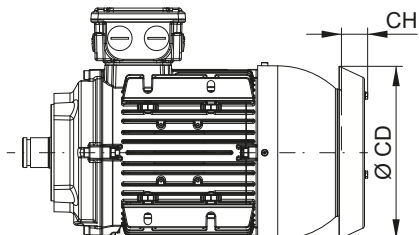

IEC frame size	ØCD	CH
63	124	20
71	139	20
80	157	20
90	176	20
100	197	32
112	219	35
132	254	35
160	266	52
180	310	57
200	380	67
225	427	72
250	427	72

Dimensions in mm.

### ID - Protection cap for encoders

IEC frame sizes: 90 to 250

If mounted outside the fan cover, the encoder may be protected against foreign matter and other external influence by a separate protection cap.

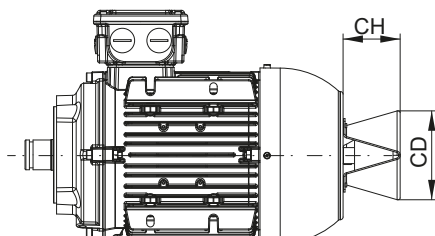

Protection cap for	CD	CH
IG standard encoder	74	116
IV Heavy Duty encoder	115	183

Dimensions in mm.

## ZW. - Second shaft end

Motors with or without brake can be supplied with a second free shaft end.

### ZWM: Module shaft

IEC frame sizes: 71 to 250. This shaft end can be used to transfer half the rated output of the motor.

### ZWV: Solid shaft

IEC frame sizes: 63 to 200. Available on request.

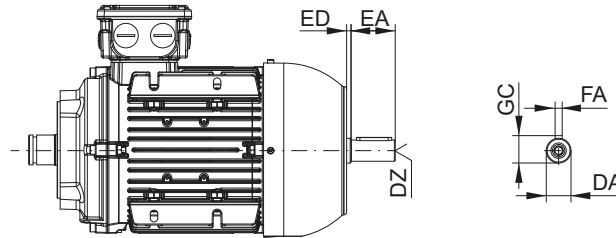

IEC frame size	DA	DZ <sup>2)</sup>	EA	ED	FA	GC
63 <sup>1)</sup>	11	M4	23	-	4	12.5
71	14	M5	30	5	5	16
80	14	M5	30	5	5	16
90	19	M6	40	5	6	21.5
100	24	M8	50	5	8	27
112	24	M8	50	5	8	27
132	28	M10	60	5	8	31
160	38	M12	80	5	10	41
180	38	M12	80	5	10	41
200	38	M12	80	5	10	41
225 <sup>2)</sup>	38	M12	80	5	10	41
250 <sup>2)</sup>	38	M12	80	5	10	41

Tolerances		
Dimension name	ISO tolerance DIN EN ISO 286-2	
DA	≤ Ø 30 mm	j6
	> Ø 30 mm up to Ø 50 mm	k6

Dimensions in mm. <sup>1)</sup> ZWV only <sup>2)</sup> ZWM only <sup>3)</sup> centre hole with thread according to DIN 332-1

## Standards

The motors comply with the competent standards and specifications, especially with the following:

Title	IEC	DIN / EN / VDE
Rotating electrical machines Rating and performance	IEC 60034-1 IEC 60085	DIN EN 60034-1
Standard methods for determining losses and efficiency from tests (excluding machines for traction vehicles)	IEC 60034-2-1	DIN EN 60034-2-1
Degrees of protection provided by integral design of rotating electrical machines (IP Code)	IEC 60034-5	DIN EN 60034-5
Methods of cooling (IC Code)	IEC 60034-6	DIN EN 60034-6
Classification of types of construction, mounting arrangements and terminal box position (IM Code)	IEC 60034-7	DIN EN 60034-7
Terminal markings and direction of rotation	IEC 60034-8	DIN EN 60034-8
Noise limits	IEC 60034-9	DIN EN 60034-9
Starting performance of single-speed three-phase cage induction motors	IEC 60034-12	DIN EN 60034-12
Mechanical vibration of certain machines with shaft heights 56 mm and higher - measurement, evaluation and limits of vibration severity	IEC 60034-14	DIN EN 60034-14
Dimensions and output series for rotating electrical machines	IEC 60072-1	DIN EN 50347
Thermal protection	IEC 60034-11	DIN EN 60034-11
CENELEC standard voltages	IEC 60038	DIN EN 60038

# Know More

Excellence to enhance productivity

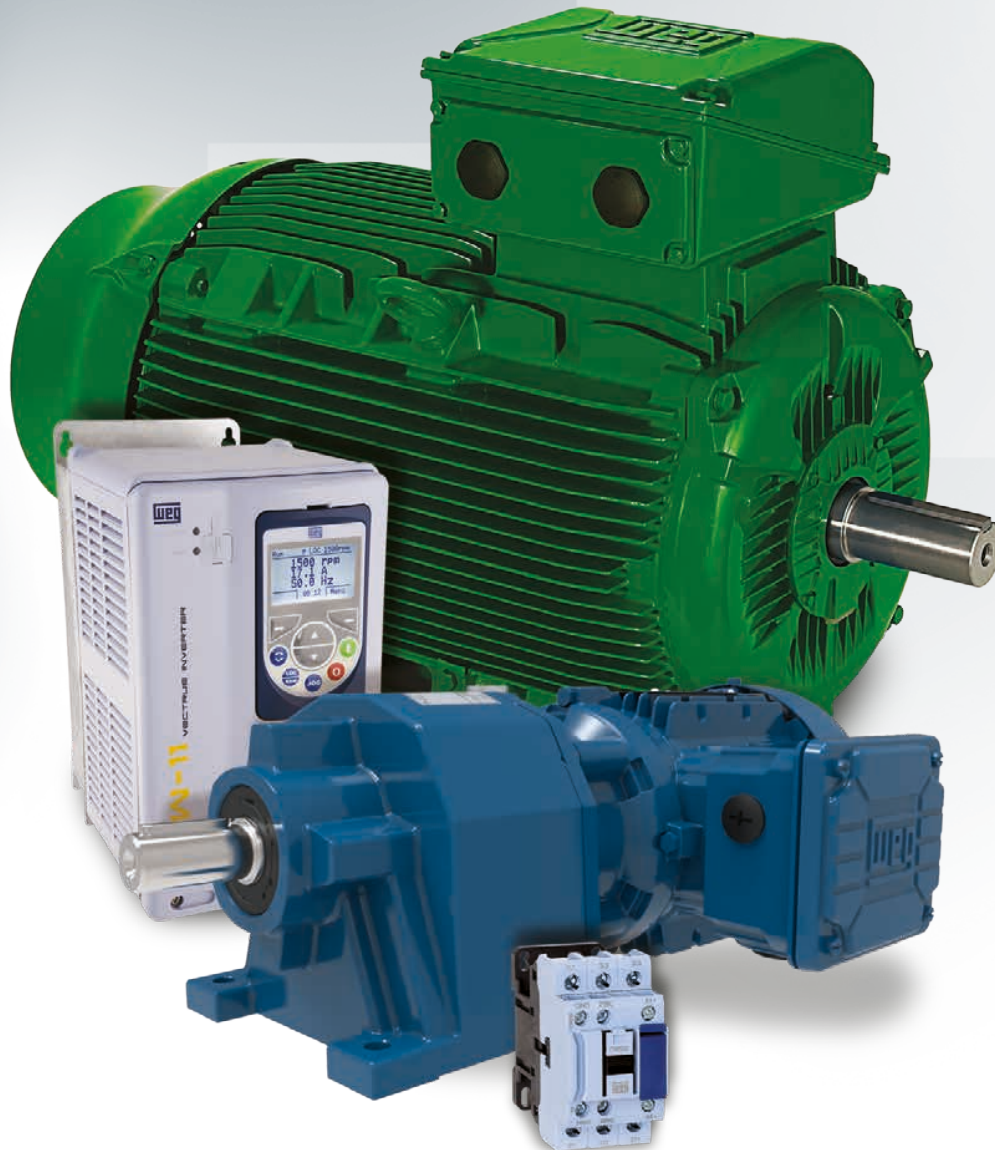

For us, excellence is to develop products and projects that increase the competitiveness of our customers, with a full range of electrical equipment, efficient and safe machines and clean and sustainable energy. We provide products with high performance and reliability to improve your production process from start to finish.

Visit: [www.weg.net](http://www.weg.net)

[youtube.com/wegvideos](https://www.youtube.com/wegvideos)